

StudioComm for Surround

Model 74 Central Controller and Model 75 Control Console

User Guide

Issue 2, January 2006

This User Guide is applicable for systems consisting of:
Model 74: serial number M74-00151 and later;
Model 75: M75-00151 and later

© 2006 by Studio Technologies, Inc., all rights reserved

www.studio-tech.com

Table of Contents

Introduction.....	5
Installation	9
Configuration	16
Operation.....	34
Technical Notes.....	39
Specifications	44
Appendix A – MIDI Messages	45
Block Diagrams	
Model 74 Central Controller	
Model 75 Control Console	

This page intentionally left blank.

Introduction

What This User Guide Covers

This User Guide is designed to assist you when installing and using the Model 74 Central Controller and the Model 75 Control Console.

StudioComm for Surround

The StudioComm for Surround Model 74 Central Controller and Model 75 Control Console work together to provide 5.1 surround and stereo source monitoring capabilities, along with a full-featured headphone “talkback” cue system. The system is a perfect fit for contemporary facilities that need to perform a variety of audio tasks. These can include surround and stereo mixing and monitoring, live recording of voice, music, and sound effects, and on-air broadcast applications. The system’s features were carefully selected to provide extensive capabilities while remaining simple to operate. Of overriding concern is maintaining the quality of the connected audio sources. This is accomplished using a combination of excellent circuit design and carefully selected components. The Model 74/Model 75 combination is ideal for adding surround monitoring capability to disk-based recording systems. It’s also well suited for upgrading a post-production or broadcast facility to support multi-channel monitoring.

A complete StudioComm for Surround 74/75 system begins with the Model 75 Control Console, a compact user control surface that is intuitive and comfortable to use. It is designed to reside at the operator’s location. The Model 75 connects to the Model 74 Central Controller using a single 9-pin cable. Occupying one rack

space, the Model 74 provides all audio input and output circuitry, signal routing and control, and power supply functions. To complete the system up to four Model 35 Talent Amplifier modules can be added. These connect to the Model 74 using standard 3-pin XLR-type audio cables. Model 35 units are typically deployed in voice-over booths, studio areas, or other locations where voice or music talent needs access to a headphone cue feed. Each unit provides a stereo audio amplifier, user controls, and support for one or two pairs of headphones.

Model 74 Central Controller

The Model 74 Central Controller is a single rack-space unit that contains analog, digital, and power supply electronics. Four analog sources can be connected: two surround (5.1) and two stereo. In many applications the first surround input, Surround A, will be connected to a multi-channel output on an audio console or digital audio workstation. The second surround input, Surround B, will be connected to a playback device, such as a multitrack tape recorder or disk storage system. For film or video post applications Surround A would be considered the direct source, while Surround B would be considered the playback source.

The two stereo inputs, Stereo A and Stereo B, are provided for general-purpose use and can be connected to a variety of 2-channel direct and playback sources. For flexibility, the surround and stereo inputs are compatible with balanced or unbalanced signals having a nominal level range of -12 dBV to $+6$ dBu. Fifteen-turn trim potentiometers are used to precisely calibrate the input signals.

The Model 74 provides two 6-channel monitor outputs. A powerful system feature is the ability to configure the monitor outputs to meet the exact needs of an installation. In a “straight-ahead” application the monitor outputs might be configured to support two independent surround (5.1) loudspeaker systems. Alternately, one surround and one stereo monitor system could be connected. However, other more unique configurations are also possible. These include supporting alternate surround monitor speaker systems or adding additional LFE or surround speakers. The monitor outputs are electronically balanced and designed for connection to audio power amplifiers or amplified loudspeakers. Protection circuitry provides power-up and power-down protection of the connected loudspeaker systems.

Audio input and output connections are made using four 25-pin D-subminiature

connectors. The Model 74’s audio path features low-noise, low-distortion analog switches for input source selection and laser-trimmed voltage-controlled-amplifier (VCA) integrated circuits for monitor level control. One 9-pin D-subminiature connector is used to connect the Model 74 to the Model 75 Control Console. A second 9-pin “D-sub” connector is used to interface remote control signals with the Model 74. The Model 74’s talent amplifier output uses a 3-pin male XLR-type connector. An infrared receiver module can connect to the Model 74 using a 3.5 mm jack.

An advanced 8-bit microcontroller provides the logic “horsepower” for the Model 74. AC mains power is connected directly to the Model 74, which is factory selected for 100, 120, or 220/240 V operation. The internal power supply utilizes two toroidal mains transformers for quiet audio operation.

Figure 1. Model 74 Central Controller Front Panel

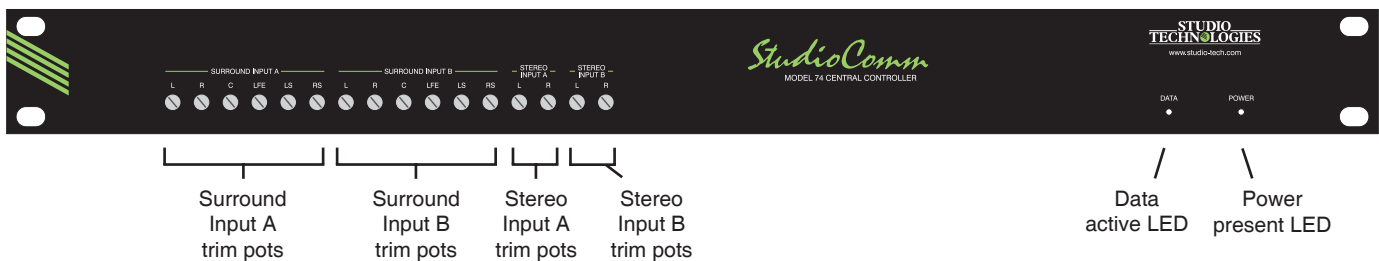

Figure 2. Model 74 Central Controller Back Panel

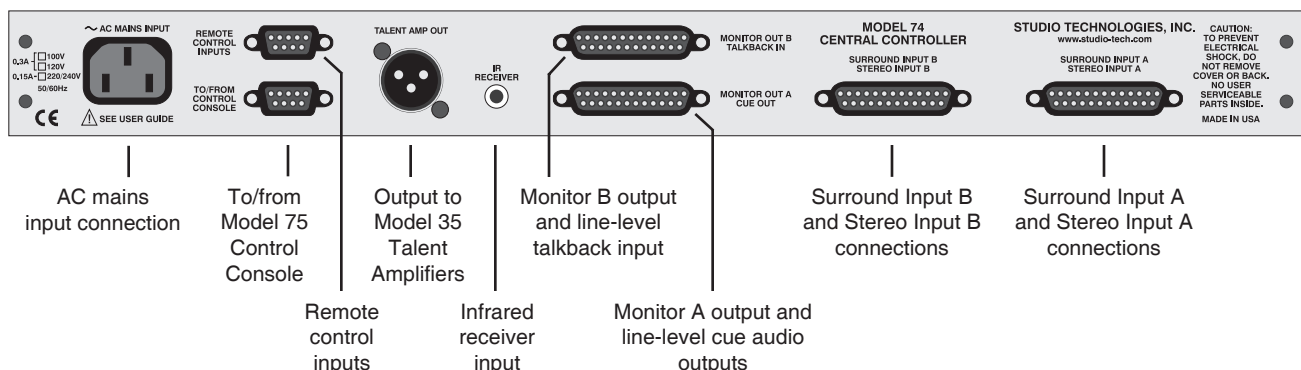
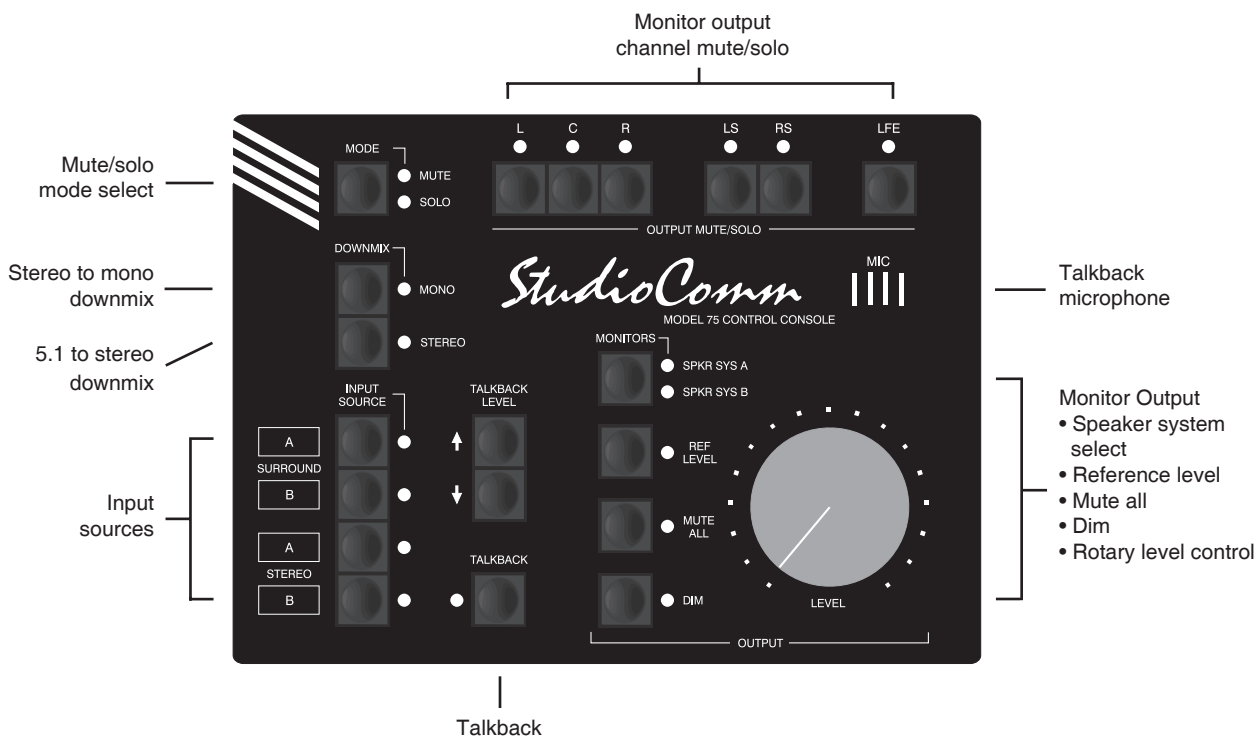

Figure 3. Model 75 Control Console Front Panel



Model 75 Control Console

The Model 75 Control Console is a compact, self-contained unit designed to be located at the operator's position. It allows fingertip control of all monitoring and talkback parameters. Numerous LED indicators provide complete status information. A major strength of the Model 75 is its ability to configure, under software control, many of the operating parameters. All configuration parameters are stored in nonvolatile memory. The Model 75 Control Console connects to, and is powered by, the Model 74 Central Controller. The Model 75 generates MIDI system-exclusive messages to control the Model 74. Remote-control signals connected to the Model 74 Central Controller are routed to the Model 75 via pins in the 9-pin interconnecting cable.

The Model 75 provides four buttons and associated LEDs for selection of the surround and stereo sources to be monitored.

While in most cases only one input source will be monitored at a time, multiple inputs can be selected for simultaneous monitoring. This allows two, three, or all four of the inputs to be combined ("summed"). While there is no independent control of the input levels, this feature can be useful for creating rough mixes from the source signals. It is also a fast, effective means of making a "seat-of-the-pants" check on the phase relationship between synchronized signals.

The monitor output levels are controlled using a large, easy-to-use rotary control. The "curve" or "taper" of the level control can be configured to match an operator's preference. The choices available are true logarithmic and modified logarithmic. The level control auto mute all function allows the monitor output channels to mute automatically whenever the rotary level control is in its fully counterclockwise (minimum)

position. This is useful in applications such as on-air broadcast. By using the reference level function, the monitor output level can be set to a pre-configured value. This is provided for audio-with-picture applications that require a specific monitor level. The reference level is easily configured by taking an electronic “snapshot” of the position of the rotary level control.

One button controls which monitor output, A or B, is active. For operator convenience, the dim function allows the monitor output level to be reduced by a fixed dB amount. The dim level is configured from four available levels. A mute all function allows all of the monitor output channels to be simultaneously muted. The mute/solo section provides individual output channel control. One pushbutton switch sets the operating mode for either mute or solo. In the mute mode, individual channels can be muted as required. In the solo mode, one channel can be monitored while the others are automatically muted. Depending on the configuration, multiple channels can be simultaneously selected for “soloing.” The flexibility of having both mute and solo available allows an operator to quickly select the most comfortable and productive operating mode.

Two functions allow the format of the monitored sources to be checked for level or phase inconsistencies. The 5.1 to stereo downmix function is used to create a stereo signal from a 5.1 (surround) source. The stereo to mono downmix function allows a stereo signal to be added (summed) and monitored. The two downmix functions can be simultaneously enabled, allowing a surround signal to be checked for mono compatibility. The operating mode of the stereo to mono downmix function can be selected from two choices:

mono-to-left-and-right or mono-to-center. This allows support for both music and audio-with-picture applications. A bandpass filter feature is associated with the stereo to mono downmix function. It is included to assist an operator in determining compatibility with “real world” playback environments. A bandpass filter can be inserted into the path of the mono signal, allowing the response of a monaural loudspeaker associated with an inexpensive television or portable radio to be simulated.

To support the headphone cue system functions the Model 75 Control Console includes three pushbutton switches and an integral microphone. As expected, one button is used to enable the talkback function. The other two buttons are used to set the talkback level over an 8-step range. These buttons are also used to select which audio source is routed to the headphones. Two choices are provided: the left and right channels of the source selected for the monitor output, or the left and right channels associated with Stereo B.

In many cases the talkback button contained in the Model 75 will be used to initiate the talkback function. However, some applications may benefit from being able to remotely activate talkback. A hard-wired signal can be connected to the remote talkback input. In this way various types of external wired and wireless equipment can be interfaced. An infrared (IR) receiver module can also be directly connected. This allows the use of a wireless transmitter to enable talkback. The microphone contained within the Model 75 Control Console provides crisp, clear talkback audio. But some installations may benefit from using an alternate source of talkback audio. This capability is provided by the Model 74’s line-level talkback audio input.

For flexibility, the system is designed to easily integrate with recording consoles, specialized playback systems, and audio-for-picture machine-control electronics. Four hard-wired remote-control input functions are provided: mute all, dim, talkback, and input select. By providing access to the StudioComm's mute all and dim functions, talkback or slate activity from an audio console or other communications system can control the monitor output level. The remote talkback input allows an externally provided contact closure or logic signal to control the talkback function. This allows easy integration with additional wired or wireless talkback devices. The remote input select function is provided expressly for audio post applications, allowing automatic switching of the StudioComm's input source whenever the mode of a recording system changes between playback and record. This function, referred to historically as PEC/direct switching, allows accurate monitoring during dialog replacement, Foley, or other overdub sessions.

In most cases Model 35 Talent Amplifier modules will serve as the user's headphone control center. Each Model 35 contains amplifier circuitry, stereo level control, mono switch, and two output jacks. For convenience, a microphone mounting stand adapter is included with each Model 35. In addition to the talent amplifier output, the Model 74 also provides a stereo line-level cue output. This allows interfacing with other headphone cue systems or could connect to a transmission system associated with a remotely located studio or control room. The line-level cue output can also serve as a source of "slate" audio for workstations.

Figure 4. Model 35 Talent Amplifier Front Panel

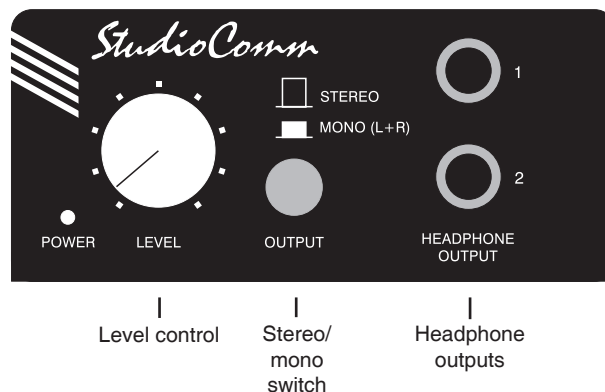
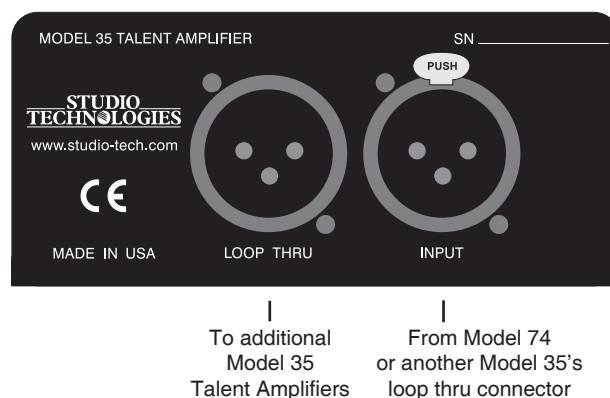

Figure 5. Model 35 Talent Amplifier Back Panel



Installation

In this section you will be installing the Model 74 Central Controller in an equipment rack. Audio input, monitor output, and headphone cue system connections will be made. One or more Model 35 Talent Amplifiers will be connected. A location will be selected for the Model 75 Control Console and it will be connected to the Model 74. If required, external equipment will be interfaced to the remote control inputs. AC mains power will be connected to the Model 74.

System Components

The shipping carton contains one each of the following: Model 74 Central Controller, Model 75 Control Console, 9-pin D-sub interconnecting cable, and user guide. Units destined for North America also include an AC mains cord. Your dealer or distributor will provide an AC mains cord for non-North American destination. Model 35 Talent Amplifiers will be contained in separate cartons.

Mounting the Model 74

The Model 74 Central Controller requires one space in a standard 19-inch equipment rack. Select a location that is convenient to both the analog audio signals and the Model 75 Control Console. A cable is provided to connect the Model 75 with the Model 74. Secure the Model 74 into the equipment rack using two mounting screws per side.

Audio Connections

Line-level audio signal connections are made by way of four 25-pin D-sub connectors, located on the Model 74's back panel. To implement all the available features four cable harnesses, each with a 25-pin D-sub plug (male) on one end and the desired connectors on the other end, are necessary. These cable harnesses are not supplied by Studio Technologies. Note that our friends in some locations may use the term "loom" instead of harness.

The wiring scheme used by the D-sub connectors comply with that made familiar by TASCAM® with their DA-88® product. Wiring harnesses prepared for connecting to the Model 74's surround and stereo inputs are identical to DA-88-style input harnesses. A wiring harness prepared for

the monitor output A and line-level cue outputs is identical to that of a DA-88-style output harness. A wiring harness prepared for the fourth D-sub is slightly different. It is used for connecting with the six channels of monitor output B as well as the line-level talkback input. As such, it will require careful attention when selecting the right terminations, e.g., six male plugs and one female connector. Please refer to Figures 6 through 11 for the exact connection details. Be certain to note that the Model 74's D-sub connectors use 4-40 threads.

Unless there's a special need, it may be cost and time effective for you to purchase commercially made cable harnesses. Let the large market for DA-88-style cabling help you painlessly install your system! There is one caveat to using pre-made harnesses. The sex of the connector associated with the line-level talkback input may need to be changed. Even so, using pre-made cables harnesses may still provide helpful.

Surround and Stereo Inputs

The connector labeled Surround Input A and Stereo Input A, as well as the connector labeled Surround Input B and Stereo Input B are used to interface with the two 6-channel (5.1 surround) and two 2-channel (stereo) input circuits. Please refer to Figures 6 and 7 for details on the exact "pin out" of the D-sub connectors. Each input circuit is electronically balanced and intended for connection to balanced or unbalanced sources with nominal signal levels of -12 dBV to +6 dBu. A 15-turn trim potentiometer is associated with each input channel, allowing the input sensitivity to be adjusted to match the source's level. The configuration section of this guide provides details on using the trim pots.

Connections	Signal High (+)	Signal Low (-)	Shield
SURROUND A-L	24	12	25
SURROUND A-R	10	23	11
SURROUND A-C	21	9	22
SURROUND A-LFE	7	20	8
SURROUND A-LS	18	6	19
SURROUND A-RS	4	17	5
STEREO A-L	15	3	16
STEREO A-R	1	14	2

- Notes:** 1) Connector type on Model 74 is 25-pin D-subminiature female. Installer must provide plug (male). Connector uses 4-40 threaded inserts for locking with mating plug.
- 2) Wiring scheme follows TASCAM DA-88 convention. Standard DA-88-type wiring harnesses are directly compatible, with the exception of 4-40 screw threads being required.

Figure 6. Connections for Inputs Surround A and Stereo A

Connections	Signal High (+)	Signal Low (-)	Shield
SURROUND B-L	24	12	25
SURROUND B-R	10	23	11
SURROUND B-C	21	9	22
SURROUND B-LFE	7	20	8
SURROUND B-LS	18	6	19
SURROUND B-RS	4	17	5
STEREO B-L	15	3	16
STEREO B-R	1	14	2

- Notes:** 1) Connector type on Model 74 is 25-pin D-subminiature female. Installer must provide plug (male). Connector uses 4-40 threaded inserts for locking with mating plug.
- 2) Wiring scheme follows TASCAM DA-88 convention. Standard DA-88-type wiring harnesses are directly compatible, with the exception of 4-40 screw threads being required.

Figure 7. Connections for Inputs Surround B and Stereo B

Balanced sources should be wired so that signal high is connected to +, signal low to -, and shield to the shield connection. With an unbalanced source, connect signal high to the + connection, and shield to both the - and the shield connections. If connecting to an unbalanced source in this manner results in hum or noise, try connecting signal high to +, and shield to -; leave the shield connection unterminated.

It is highly recommended that at least one of the surround inputs be wired by way of an audio patch bay. This will allow the channels associated with that input source to be easily rerouted. While signals generated within a facility will normally follow a specific format, such as left, right, center, LFE, left surround, and right surround, it is possible that media provided by an outside facility will follow a different scheme.

Monitor Outputs

Two connectors are used to support the two 6-channel (5.1 surround) monitor outputs. Please refer to Figures 8 and 9 for details on the exact "pin outs" of the D-sub connectors.

The monitor output channels are intended for connection to audio amplifiers associated with monitor loudspeakers, or to the inputs of loudspeakers that contain integrated amplifiers. The monitor outputs are electronically balanced and capable of driving balanced or unbalanced loads of 600 ohms or greater. While balanced operation is preferred, unbalanced operation does not pose a problem. To connect to an unbalanced load connect the + terminal as signal high, and both the - and shield as the signal low/shield. For optimal unbalanced operation, it is important to connect both - and shield together directly on the D-sub plug, not at the other end of the harness.

Connections	Signal High (+)	Signal Low (-)	Shield
MONITOR OUT A-L	24	12	25
MONITOR OUT A-R	10	23	11
MONITOR OUT A-C	21	9	22
MONITOR OUT A-LFE	7	20	8
MONITOR OUT A-LS	18	6	19
MONITOR OUT A-RS	4	17	5
CUE OUT-L	15	3	16
CUE OUT-R	1	14	2

- Notes:** 1) Connector type on Model 74 is 25-pin D-subminiature female. Installer must provide plug (male). Connector uses 4-40 threaded inserts for locking with mating plug.
2) Wiring scheme follows TASCAM DA-88 convention. Standard DA-88-type wiring harnesses are directly compatible, with the exception of 4-40 screw threads being required.

Figure 8. Connections for Monitor Output A and Line-Level Cue Outputs

Connections	Signal High (+)	Signal Low (-)	Shield
MONITOR OUT B-L	24	12	25
MONITOR OUT B-R	10	23	11
MONITOR OUT B-C	21	9	22
MONITOR OUT B-LFE	7	20	8
MONITOR OUT B-LS	18	6	19
MONITOR OUT B-RS	4	17	5
UNUSED	15	3	16
TALKBACK INPUT	1	14	2

- Notes:** 1) Connector type on Model 74 is 25-pin D-subminiature female. Installer must provide plug (male). Connector uses 4-40 threaded inserts for locking with mating plug.
2) Wiring scheme follows TASCAM DA-88 convention. Standard DA-88-type wiring harnesses are directly compatible, with the exception of 4-40 screw threads being required.

Figure 9. Connections for Monitor Output B and Line-Level Talkback Inputs

Note that while the Model 74's electronically balanced output circuits are capable of driving loads of 600 ohms or greater, the output level will drop slightly as the load impedance approaches 600 ohms. A 0.5 dB difference in output level can be expected as the load impedance changes from 10 k ohms to 600 ohms. This drop is not insignificant and leads to the recommendation that input loads be 10 ohms or greater.

It's important to note that the two 6-channel monitor outputs can be used to create a wide variety of monitor system implementations. Configuration choices allow the two outputs to perform tasks more nuanced than just serving as a 6-channel A/B switching matrix. Please carefully review the configuration section of this user guide prior to connecting to the monitor outputs; don't let the system's unique flexibility go underutilized!

Headphone Cue System

Two outputs and one input are associated with the headphone cue system. The talent amplifier output supplies audio and DC power for supporting Model 35 Talent Amplifier units. Using this method a great-sounding, flexible cue system can be easily created. A stereo line-level output associated with the headphone cue system is also available. A source of line-level audio can be connected and can serve as the talkback audio source. This source can be used in place of the microphone contained in the Model 75 Control Console.

Talent Amplifier Output

Up to four Model 35 Talent Amplifiers can be connected to the Model 74's talent amplifier output. The output connector is a 3-pin male XLR-type. For best performance, use low-capacitance shielded microphone-type

cable to distribute the talent amplifier signal. If there is a choice, select cables with the heaviest wire gauge commonly available. This will reduce voltage drop when using long cable runs. Refer to the Technical Notes section for additional information.

The simplest installation would use a microphone cable to connect the Model 74 to the first talent amplifier; the loop through connector on that talent amp sending the signal on to the next talent amp.

For convenience, you may want to wire your facility to allow easy access to the talent amplifier signal at all locations where talent amplifiers might be used. The talent amplifiers connect to the Model 74 in parallel, so the connectors on the distribution panels or mult boxes should be wired in parallel.

Warning: Do not connect the Model 74's talent amplifier output to anything but Studio Technologies' talent amplifiers. Some audio equipment may be damaged by the DC voltage contained on pin 2 of the talent amplifier output connector.

Included with each Model 35 Talent Amplifier is a nifty mounting adapter that allows the unit to be conveniently attached to a microphone stand. Please refer to the documentation provided in the Model 35's shipping carton for details.

Line-Level Cue Output

A 2-channel (stereo) line-level output provides access to the headphone cue system signals. The line-level cue output channel is intended for connection to an audio amplifier associated with a headphone cue system. It could also

be useful for connecting with a remotely located studio or production facility. Using ISDN or IP-based technology, being able to send audio signals to literally any part of the world has become a fairly simple task. The headphone cue signals are accessible on one of the 25-pin D-subminiature connectors, located on the Model 74's back panel. Please refer to Figure 8 for details on the exact "pin out" of the D-sub.

The line-level cue outputs are electronically balanced, capacitor coupled, and intended to drive balanced or unbalanced loads of 600 ohms or greater. While balanced operation is preferred, unbalanced operation does not pose a problem. To connect to an unbalanced load connect the + terminal as signal high, and both the – and shield as the signal low/shield.

Note that while the line-level cue outputs are electronically balanced, signal is only driven on the + connection. The – connection serves only as a signal-balancing return path. This simplified output circuit was deemed appropriate for headphone cue system applications. It provides good audio quality even though its circuitry is not as sophisticated as that used by the monitor output channels.

Line-Level Talkback Input

An alternate source of talkback audio can be connected to the Model 74. This audio source can be used instead of the microphone contained in the Model 75. A configuration parameter selects which source is active.

The audio source should have a nominal level of +4 dBu and can be balanced or unbalanced. Pins on one of the 25-pin D-subminiature connectors are used to connect the signal. Refer to Figure 9

for details. Balanced sources should be wired so that signal high is connected to +, signal low to –, and shield to the shield connection. With an unbalanced source, connect signal high to the + connection, and shield to both the – and the shield connections. If connecting to an unbalanced source in this manner results in hum or noise, try connecting signal high to +, and shield to –; leave the shield connection unterminated.

Remote Control Inputs

Support is provided for four hard-wired remote control input functions: mute all, dim, talkback, and remote input select. The inputs are “pulled up” to +5 volts DC by way of resistors and are active when brought to the logic low state. Inputs of this type are commonly referred to as GPI inputs. While the input circuitry is protected from over-current and static (ESD) discharge, care should be taken to prevent nasty signals from reaching them. The inputs are active only when held in the low state; they can’t be configured to change state (“latch”) in response to a logic pulse.

A female 9-pin D-subminiature connector, labeled Remote Control Inputs, is located on the back panel of the Model 74. It is used to interface with the four remote control inputs. Refer to Figure 10 for exact connection details. Note that pin 1 (shield) and pin 9 (remote control common) are electrically identical. In addition to connecting to system common, they connect to the Model 74’s chassis and mains earth connection. For convenience, the shield of the interconnecting cable should be connected to pin 1 (shield), while the return signals of the remote control sources should connect to pin 9 (remote control common).

Pin	Signal
1	Shield
2	Spare A (to Model 74)
3	Spare B (to Model 74)
5	Remote Mute All (to Model 75)
6	Remote Dim (to Model 75)
7	Remote Talkback (to Model 75)
8	Remote Input Select (to Model 75)
9	Remote Control Common (to Model 75)

Notes: 1) Connector type on Model 74 is 9-pin D-subminiature female. Installer must provide plug (male). Connector uses 4-40 threaded inserts for locking with mating plug.

Figure 10. Connector Pin Out for Remote Control Inputs

Note that although the remote control connections are physically made to the D-sub on the Model 74’s back panel, the remote control input circuitry is actually located in the Model 75 Control Console. Conductors in the cable linking the Model 74 to the Model 75 route the remote control signals to the actual input circuitry.

Connecting the Model 74 to the Model 75

A cable with 9-pin D-sub plugs (males) on each end is used to interconnect the Model 74 Central Controller with the Model 75 Control Console. A cable, approximately 20-feet (6.1-meters) long, is provided with each system. The connector labeled To/From Control Console on the back panel of the Model 74 is used to connect to the Model 75.

Should a cable of different length be required, it should be wired in a one-to-one fashion for all nine pins. Pin 1 serves as signal common and must be connected at both ends. A shield connection for the

Pin	Signal	Direction
1	Power Supply Common	74 to/from 75
2	+15 Volts DC	74 to 75
3	Data (MIDI System-Exclusive)	75 to 74
4	Data Common	74 to/from 75
5	Remote Mute All	74 to 75 (Note 2)
6	Remote Dim	74 to 75 (Note 2)
7	Remote Talkback	74 to 75 (Note 2)
8	Remote Input Select	74 to 75 (Note 2)
9	Talkback Mic Audio	75 to 74

Notes: 1) Connector types on Model 74 and Model 75 are 9-pin D-subminiature female. Connectors use 4-40 threaded inserts for locking with mating plug.

2) Remote control sources connect to D-sub on Model 74, then passively route to Model 75 via 74/75 interface D-sub.

Figure 11. Connections between Model 74 and Model 75

cable should also be connected to pin 1 on the Model 74's end. For best performance the cable generally should not exceed 50 feet (15.3 meters) in length.

The reality is that a cable longer in length than 50 feet should work correctly, as long as an excellent-quality cable is utilized. We define "excellent" as extensive shielding along with very low capacitance. The low cable capacitance is important as it limits the amount of data-signal waveform distortion. As far as determining an actual maximum length, just test and see how far away you can go—if it works, it works! A termination resistor connected from pin 3 to pin 4 at the Model 75's end of the interconnecting cable may help to support a longer cable "run." The value of the termination resistor should be in the range of 3.3 k (3300) to 10 k (10000) ohms. A commonly available ¼-watt, 5% tolerance resistor is perfectly acceptable.

Infrared Remote Control Input

An infrared (IR) receiver module can be directly connected to the Model 74. This allows, with an appropriate IR transmitter, wireless activation of the talkback function. The IR receiver connects to the Model 74 using a 3.5 millimeter 3-conductor jack which is located on the back panel. The jack complies with the standard convention for IR receiver modules: data on the tip lead, ground on the ring lead, and 12 volts DC on the sleeve lead. Compatible modules are available from a number of companies. As an example, the Xantech® 291-80 looks nice and works adequately. For excellent performance under compact florescent lighting conditions the Russound® SaphIR 860 Phantom has proven its worth.

For correct wireless talkback operation selecting and programming a compatible transmitter is necessary. Refer to the Configuration section of this user guide for details.

AC Mains Power

The Model 74 is internally configured to operate from an AC mains power source of nominal 100, 120, or 220/240 volts, 50/60 hertz. Units shipped to North America are factory selected for 120 volt operation. Units bound for Japan must be selected for 100 volts, while our friends "down under" and in Europe receive units set for 220/240 volts. Before connecting the Model 74 to AC mains power, check that it is configured to match the local mains voltage. Look on the back panel (adjacent to the power entry connector) for the factory-configured voltage. Note that an incorrect configuration could prevent operation, or cause damage to the unit. Should it be necessary to change the unit's operating voltage it must

be performed only at the factory or by a competent service technician.

The Model 74 uses an IEC-320 C14-compatible connector to mate with the AC mains cord. The wire colors in the AC mains cord should conform to the internationally recognized CEE color code and must be wired accordingly:

<u>Connection</u>	<u>Wire Color</u>
Neutral (N)	Light Blue
Line (L)	Brown
Protective Earth (E)	Green/Yellow

Safety Warning: The Model 74 does not contain an AC mains disconnect switch. As such, the AC mains cord plug serves as the disconnection device. Safety considerations require that the plug and associated outlet be easily accessible to allow rapid disconnection of AC mains power should it prove necessary.

As soon as AC mains power is applied, the Model 74's power present LED will flash for a few seconds. After the completion of a software startup interval the power present LED will light steadily. The data active LED on the Model 74 will flash once upon power up, then briefly light upon completion of the Model 75's power-up sequence. The Model 75 will go through its own power-up sequence, lighting each LED in succession.

Configuration

After the physical installation has been completed, several configuration issues must be addressed. On the Model 74 the surround and stereo inputs must be calibrated using the trim potentiometers. The

operating parameters of the system should be set using the Model 75 Control Console's configuration mode.

Level Calibration

Sixteen 15-turn trim potentiometers are located on the front panel of the Model 74 Central Controller. Taking time to carefully adjust the trim pots will ensure that accurate monitoring can take place. Each trim pot allows input signals with a nominal level of -12 dBV to $+6$ dBu to be utilized. With care, it's easy to calibrate the surround and stereo inputs to within one-quarter of a dB of the desired value.

The monitor outputs are used as the measuring point when adjusting the trim pots. A laboratory-grade audio level meter or equivalent is required for accurate calibration. In addition, the audio sources connected to the inputs must be able to generate continuous audio signals at their nominal operating level.

Procedure

This procedure will calibrate the surround and stereo input channels. The trim pots will be adjusted in groups corresponding to their associated input sources.

1. Begin by turning the audio amplifiers or amplified speakers to their off state. This will protect the loudspeakers and the operator's ears from possible damage.
2. Rotate the level control on the Model 75 to the fully clockwise (maximum) position.
3. Using the Model 75 Control console, select Surround A as the input source and Speaker System A as the selected monitor output.

4. On the Model 74, connect the audio level meter to the left channel of monitor output A.
5. Confirm that the audio source's left channel is generating a steady signal at precisely its reference level.
6. Observing the level meter, adjust Surround A, trim pot L, to give a precise +4 dBu level at the left channel output of monitor output A.
7. Disconnect the level meter from the left channel of the monitor output.
8. Repeat steps 4-7 for the right, center, LFE, left surround, and right surround channels of Surround A.
9. Repeat steps 3-8 for Surround B, Stereo A, and Stereo B. Obviously, the stereo inputs have only left and right channels, requiring only that two trim pots be adjusted for each.
10. After the calibration procedure has been completed, rotate the level control on the Model 75 to the fully counterclockwise (minimum) position.
11. After ensuring that the Model 75's level control is set to minimum, return AC mains power to the power amps or amplified speakers.

Model 75 Operating Parameters

Many StudioComm functions can be configured to meet the exact needs of your installation. Here's an overview of what you can configure:

- Input channels active
- Speaker systems/monitor outputs
- Talkback
- Solo

- Power-up mute all
- Level control response
- Level control audio mute all
- Reference level
- Remote input select
- Dim level
- Remote mute all
- Remote dim
- Remote talkback
- Auto dim off
- Talkback dim
- Mono

The Model 75 configuration diagrams, located at the end of this section, give details on how each parameter is set. An overview of each configurable parameter is provided in the following paragraphs.

Entering and Exiting the Configuration Mode

A small button is located on the back of the Model 75 Control Console, adjacent to the 9-pin D-sub connector. Pressing and holding this button for two seconds places the Model 75 into the configuration mode. In the configuration mode the Model 75's array of buttons and LEDs no longer perform their normal functions, but instead allow you to observe and change many of the operating parameters. The mute/solo mode LEDs light alternately to indicate that the configuration mode is active.

To leave the configuration mode and return the Model 75 to normal operation, once again press and hold the configure button for two seconds. Note that configuration changes are stored only after the configuration mode has been exited.

Our apologies to those of you who find the configure button a pain to use, but it's supposed to be that way! Seriously, the top of the button is slightly recessed from the back panel, making it harder to accidentally activate. We didn't want normal operation to cease because someone pushed the Model 75 into a "rats nest" of music scores or track sheets!

There is no problem frequently "tweaking" the Model 75's operating parameters to achieve the desired performance. The configuration data is stored in nonvolatile memory, which is rated for thousands of read and write cycles and a retention time in tens of years.

Input Channels Active

This configuration is a bit tricky to understand, but is really quite simple. The configuration parameter for the number of channels active for each input is provided for those special cases where a source has less channels than its usual, e.g., less than six for Surround A or B.

Let's look at an example. Surround A is connected to a 6-channel source, so its default configuration is fine. But the source for Surround B is special, having only three channels: left, center, and right. This makes it not so "cool" for the operator to select Surround B for monitoring, as the unconnected left surround, right surround, and LFE channels will get routed to their respective monitor outputs. Will the unused input channels pick up significant noise or hum? Unlikely, but why take a chance at having a problem. Simply use the input channels active configuration function to disable the three unused channels. Now when Surround B is selected, only the appropriate channels are selected for monitoring.

Note that when a channel associated with an input is disabled the input routing circuitry, under software control, no longer selects it, but the corresponding monitor output channel does not mute. With our example, when selecting Surround B, our mythical L/C/R source, all selected monitor output channels will remain active, but the input routing circuitry won't enable the LS, RS, and LFE inputs. While to some people this might seem confusing and possibly a design fault, it was implemented this way because the StudioComm system allows multiple inputs to be simultaneously selected for monitoring; a surround source might be selected at the same time as a stereo source. Muting the outputs in response to a single input channel being selected simply would not do!

A special mode has been included to disable an input from being accessed by the operator. This might be useful, for example, when Stereo B is not connected to a source, and has no valid reason to be selected. This might also be useful when connecting a special source, such as a house "tie line" or router output, that shouldn't normally be accessible. Disabling an input is simple to perform, just disable all channels associated with it; six for Surround A and B, two for Stereo A and B. To confirm that an input has been disabled, all LEDs associated with that input will flash on and off. Once the Model 75 is returned to the normal operating mode the disabled input cannot be selected.

Speaker Systems/Monitor Outputs

The configuration parameters associated with the speaker system selection button and monitor output channels offer an extremely powerful resource. With just a few button presses a wide range of monitor system implementations can be easily

created. But spending time establishing the goals, and what steps are needed to achieve them, can prove very valuable. Studying the configuration chart may at first be confusing but should soon cause comments such as “cool” and “wow, I can really do that?” to spill out!

Physically, the Model 74 Central Controller supports the connection of two 6-channel monitor loudspeaker systems. They are designated A and B. This means that there are two output connections for each channel, e.g., two for left, two for right, two for center, etc. On the Model 75 Control Console a pushbutton allows speaker system A or speaker system B to be selected. The configuration parameters allow which of the twelve physical outputs are active when speaker system A is selected, and which of the twelve physical outputs are active when speaker system B is selected. There are no restrictions on what outputs are active in any situation.

Talkback

Four configurable parameters are related to the talkback function. The talkback button on the Model 75 can be configured to operate in either a push-to-talk or latching (push on/push off) mode.

The talkback function can be set to add (sum) talkback audio with the selected cue source. Alternately, it can be configured so that talkback audio will interrupt and replace the cue source whenever the talkback function is enabled.

The talkback audio source can be selected from two choices. In most cases it's appropriate to use the microphone contained in the Model 75. For more specialized applications a source connected to the line-level talkback input can be effective.

A configuration option enables or disables the ability to send a source of cue audio to the talent amplifier and line-level cue outputs. Typically this option will be set for enable. In certain situations it may be desirable to only send talkback audio out the talent amplifier and line-level talkback outputs. An example of where this setting could be appropriate is when one of the line-level talkback outputs is used, along with an amplifier and loudspeaker, to create a “stage announce” signal.

Solo

Solo operation can be configured to satisfy operator preference. The additive solo mode matches the functionality found in most recording consoles. In this mode, multiple channels can be simultaneously “soloed,” allowing those channels to be monitored at the same time. Other operators may prefer the exclusive solo mode. When this mode is selected, only one channel can be selected for solo at a time. The additive solo mode is the default setting.

Power-Up Mute All

By default, upon application of AC mains power the monitor outputs remain muted after the system's power-up sequence has been performed. Then an operator must manually press the mute all button to enable the monitor outputs. There may be cases where having the monitor output channels return to their respective states as left at the time of the previous loss of AC mains power, allowing normal operation automatically to resume.

Level Control Response

As expected, the level control on the Model 75 Control Console is used to adjust the output level of the monitor output

channels. The amount of rotation required to reach a specific level can be selected from two modes. This can be described as allowing the “curve” or “taper” of the level control to be configured. The two available modes are true logarithmic and modified logarithmic. In the true logarithmic mode the level control provides a precise logarithmic performance over its entire rotation, e.g., the output level is half of its maximum when the control is set at its midpoint, i.e., 50% of its “travel.” In the true log mode, normal listening may require the level control to be set to approximately the “2-o’clock” position.

Other users may be more comfortable with the response given by the modified logarithmic mode. This provides a much greater output level during the first 50% of the level control’s travel. When configured for the modified log mode, normal listening may require the level control to be set to the 11- or 12-o’clock position. The modified log mode more closely matches the monitor level control performance found in many audio consoles. As such it is selected as the default mode.

It’s important to note that changing the level control response mode will impact the reference level. Changing from modified log to true log, or vice-versa, will change the reference level. Technically, the mathematical value stored as the reference level does not change, but the loudness that is heard by the operator will change. Be warned! Changing the level control response may require the reference level to be recalibrated.

Level Control Auto Mute All

The level control auto mute all function automatically mutes the monitor output channels whenever the rotary level control

is in its fully counterclockwise position. In some applications it may be desirable to disable this function. When disabled the rotary level control adjusts the monitor output level over the approximately 72 dB range; no automatic muting takes place.

Reference Level

For audio-with-picture applications it’s critical that mixing be done in reference to a known monitor loudspeaker level. This is often referred to as mixing to “85 dB” on the monitors. The Model 75 Control Console allows a precise monitor output level setting to be stored, and then enabled by pressing the button labeled Ref Level. Setting the reference level is very simple:

1. Set up a precision sound pressure level (SPL) measuring device at the desired listening location.
2. Place the StudioComm system in the normal operating mode, not the configuration mode. Be certain that the reference and dim functions are not active.
3. Use the Model 75 Control Console to select the input source that contains the desired reference signal source, e.g., pink noise.
4. Select the desired monitor output, speaker system A or B.
5. Observing the SPL meter, adjust the Model 75’s rotary level control until the desired reference output level has been reached.
6. Being careful not to touch the position of the rotary level control, enter the configuration mode by pressing and holding the configuration button located on the Model 75’s back panel.

7. Once the configuration mode has been entered, the monitor outputs will mute. Press and hold the reference button until its associated LED lights. This will take approximately five seconds. The LED will light to indicate that a “snapshot” of the new reference level has been taken.
8. To store the new reference level in memory, exit the configuration mode by again pressing and holding the configure button.

This level is now permanently stored as the reference level. Only by repeating the procedure can the value be changed.

Once the configuration mode has been exited, the monitor output channels will again become active. Confirm that the correct level has been stored by pressing the reference button. The SPL meter should again display the desired level. If not, repeat the calibration procedure.

You might wonder why you have to press and hold the reference button for five seconds before the selected value is stored. This is provided specifically so that some careless person won't accidentally change the reference level while they are “playing around” in the configuration mode! Only if you know the “secret” will you be able to store a new value.

Remote Input Select

The remote input select function requires configuring two parameters: mode and input to be selected. The mode can be selected from three choices: disabled, exclusive, and non-exclusive. As expected, when configured for disabled, the function cannot be activated. When configured for exclusive, whenever the function is activated only the specified input will be active.

When configured for non-exclusive, whenever the function is activated the specified input will be added (summed) with any other input or inputs that are already active. The input can be selected from among the two surround and two stereo input sources.

Dim Level

The dim function is used to reduce the monitor output level by a preset amount. The reduction is in dB relative to the monitor output's current level. There are four dim level values available: 10, 15, 20, and 25 dB.

Remote Mute All

Two configuration choices are associated with the remote mute all function: disabled and enabled. To utilize the function simply configure it for enabled.

Remote Dim

Two configuration choices are associated with the remote dim function: disabled and enabled. To utilize the function simply configure it for enabled.

Remote Talkback

Two configuration choices are associated with the remote talkback function: disabled and enabled. To utilize the function simply configure it for enabled. Note that this setting applies to both the hard-wired remote talkback input and the infrared (IR) receiver talkback input. The function must be enabled for either of these inputs to be active.

Auto Dim Off

The auto dim off function is unique, making the dim function respond to real-world operating conditions. When enabled, the

function automatically turns the dim function off if a change is made to the control room level potentiometer while the unit is already in dim mode. This prevents a heart-stopping blast of audio when an engineer presses the dim button to turn dim on, but actually turns it off because the unit was already in the dim mode. While it's hard to explain unless you've used a console and experienced this in person, trust us, this situation does happen! Auto dim off is a wonderful "real-world" function and in most cases should be enabled.

Talkback Dim

The talkback dim mode selects whether the dim function is enabled whenever the talkback function is active. In most applications it's desirable to have the monitor loudspeakers dim whenever talkback is active. This ensures that headphone cue system users will clearly hear voice cue signals, rather than being overwhelmed with audio signals coming from the loudspeaker system. However, there may be special applications where it's not desirable for dim to enable when talkback is active. This could include the case where the monitor system is normally set by a user to operate at a very low SPL level.

Stereo to Mono Downmix Modes

The stereo to mono downmix operating mode can be selected from two choices: mono-to-left-and-right or mono-to-center. For music mixing it's common to have a mono function combine (sum) the signals from the left and right, or 5.1 downmixed to left and right, channels and route the result to both the left and right output channels. For broadcast and cinema use, it may be more appropriate to combine the left and right signals and route the result to the monitor system's center channel. By

default the mode is set to the mono-to-center mode.

Mono Attenuation

To meet the needs of the operator and specific program content, an attenuation level when mono-to-center is active can be configured. The choices are 0, 3, 4, and 6 dB. Selecting 0 dB is equivalent to the attenuation function being disabled. This results in no attenuation occurring when stereo to mono downmix is active. This is provided for those special cases when the stereo to mono downmix mode is set to mono-to-center and no phase coherent signals are expected to be part of the left and right, or 5.1 downmixed to left and right, channels. While the 0 dB setting is not generally appropriate for music mixing, it may find use in broadcast and cinema applications. The 3 dB and 4 dB settings are good choices for the mono-to-center mode when monitoring mixes that have significant phase coherence, such as music sources. The 6 dB setting is provided for compatibility with the mono function found on many audio consoles. As the factory default, the 3 dB attenuation value was selected.

Auto 5.1 to Stereo Downmix

The 5.1 to stereo downmix function can be configured to automatically enable whenever the stereo to mono downmix function is enabled. This is provided to ensure accurate monitoring of 5.1 sources when stereo to mono downmix is enabled. This is the default mode, although it can be changed as desired.

Restore Factory Defaults

The restore factory defaults function is provided primarily for factory use. In this way a system can be shipped with the default

settings selected. While you are welcome to use this function, be careful so that your configuration efforts aren't wasted. Specifically, be aware that the reference level is reset to minimum level. All the other parameters are fairly easy to set up, but resetting the reference level would require getting out an SPL meter and a calibrated signal source. This is a hassle you may not need!

Infrared Transmitter Configuration

To support the infrared (IR) remote talkback function an IR transmitter module must be obtained and configured. As of the writing of this user guide Studio Technologies' does not offer such a device. The Model 75's software was designed to support the use of many 3rd-party "universal" remote controls. Units from retailer RadioShack®, priced as low as US\$10, have been used successfully. For a talkback command to be recognized the remote control should be programmed to emulate an RCA DVD player's play command. (It's also possible that a setting for the Microsoft® Xbox® will also work!) The universal remote may offer several choices for this sequence. A little experimentation may be required so that a compatible emulation is selected. The Model 74 requires a baud rate of 650.

Model 75 Configuration—Entering and Exiting Configuration Mode

 Press and hold the configuration button for two seconds to enter or exit the configuration mode.

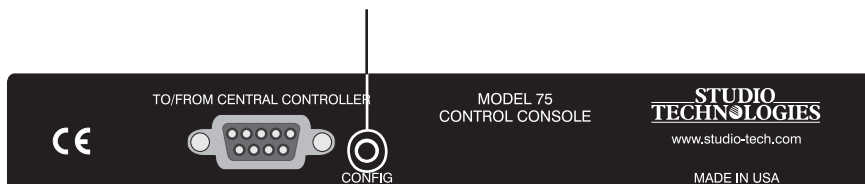

These LEDs will light alternately when configuration mode is active.



Model 75 Configuration—Input Channels Active



Press and hold an input button (one at a time) to display and select which channels associated with that input are active.

When an input button is pressed, these LEDs display which input channels are active for that input. A lit LED indicates that the channel is active. Use the buttons to change the configuration.



Default: For Surround A and Surround B, all six channels (L, C, R, LS, RS, LFE) are active. For Stereo A and Stereo B, both channels (L, R) are active.

Note: A special input disable function is available. By disabling all channels associated with a specific input, that input will no longer be available during normal operation. While in the configuration mode, all LEDs associated with an input will flash to indicate that the input has been disabled. This function is useful if an input is not going to have a source associated with it. Then during normal operation this input cannot be selected, minimizing any confusion caused by selecting an invalid input source.

Model 75 Configuration—Speaker Systems/Monitor Outputs

When an output button is pressed, these LEDs display which output(s) are assigned to speaker systems A and B:

Press Surround A button to assign output A to speaker system A;
 Press Surround B button to assign output B to speaker system A;
 Press Stereo A button to assign output A to speaker system B;
 Press Stereo B button to assign output B to speaker system B.

A lit LED indicates that the output is assigned to that speaker system.

 Press and hold an output button (one at a time) to display and select which output channels are assigned to speaker systems A and B.

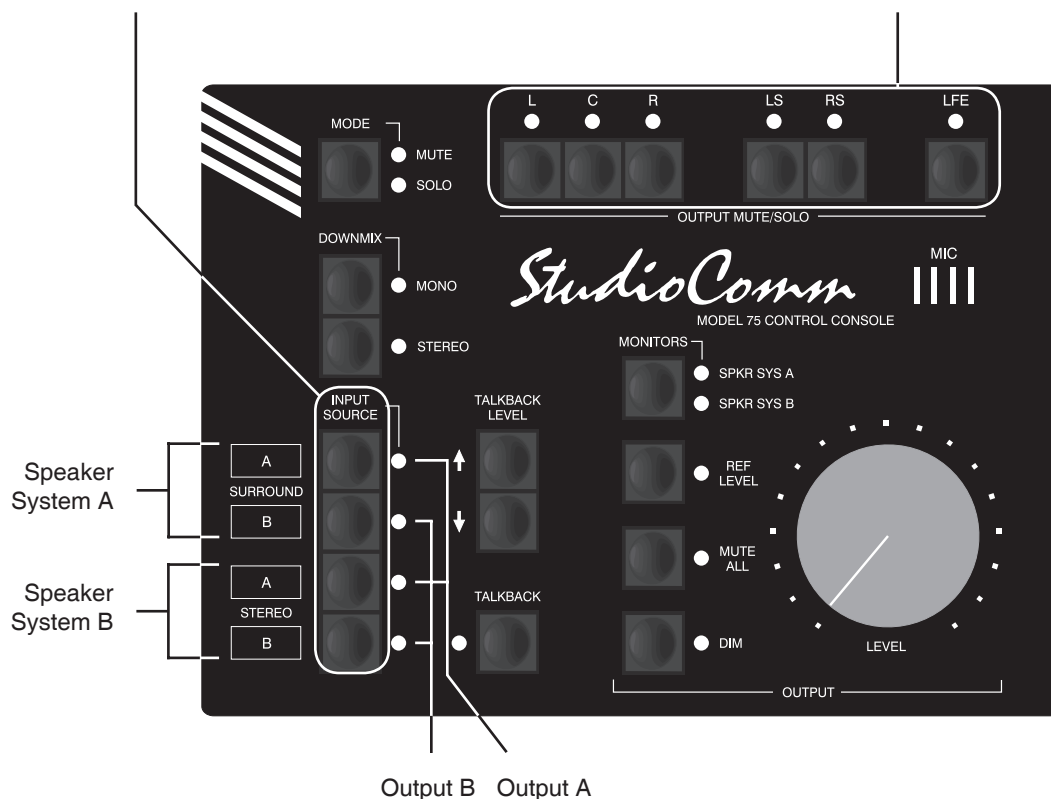

Default: For Speaker System A all six channels are assigned to output A only.
 For Speaker System B all six channels are assigned to output B only.

Note: A special output disable function is available. By disabling all outputs associated with either speaker system A or B, that system will no longer be available during normal operation. This function is useful if only one output is going to be utilized. Then during normal operation this output cannot be selected, minimizing any confusion caused by selecting an invalid speaker system.

Model 75 Configuration—Talkback

While holding the Talkback button, these LEDs display the status of the talkback audio source. Press the Surround A button to select Model 75 mic as talkback source. Press Surround B to select Aux TB In as talkback source. Surround A LED lit indicates Model 75 mic as talkback source. Surround B LED lit indicates Aux TB In as talkback source.

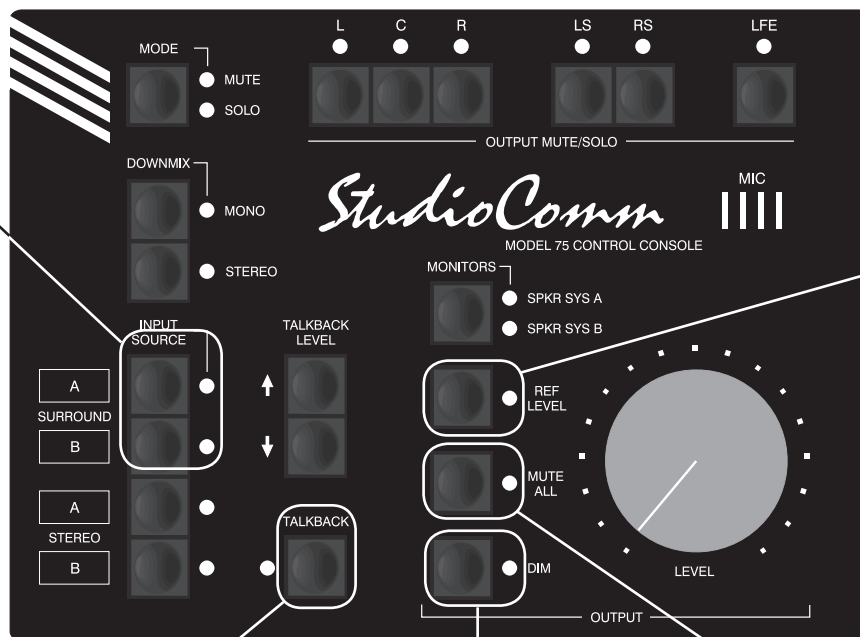

While holding the Talkback button, press the Ref Level button to enable or disable cue audio program source; LED on means cue audio program source enabled.



Press and hold the Talkback button to display and configure talkback functions.

While holding the Talkback button, press the Dim button to toggle between latching or momentary operation; LED on means the button is set to latch.

While holding the Talkback button, press the Mute All button to toggle between talkback adds to or talkback interrupts cue audio; LED on means talkback interrupts.

Default: Talkback button is set for momentary operation.
Talkback adds to cue audio mode enabled.
Talkback audio source is Model 75 mic.
Cue program audio enabled.

Model 75 Configuration—Solo, Power-Up Mute All, Level Control Response, and Level Control Auto Mute All

When the Speaker System A/B button is pressed, these LEDs display the status of the solo mode. When LED L is lit additive solo mode is enabled; when LED C is lit exclusive solo mode is enabled. Use the buttons to change the configuration.

When the Speaker System A/B button is pressed, these LEDs display the status of the power-up mute all function. When LED R is lit the state of mute all is saved at power down and followed upon power up; when LED LS is lit the system is always in mute all upon power up. Use the buttons to change the configuration.

When the Speaker System A/B button is pressed, these LEDs display the status of the level control response mode. When LED RS is lit the level control provides a true logarithmic response. When LED LFE is lit the level control provides a modified logarithmic response. Use the buttons to change the configuration.

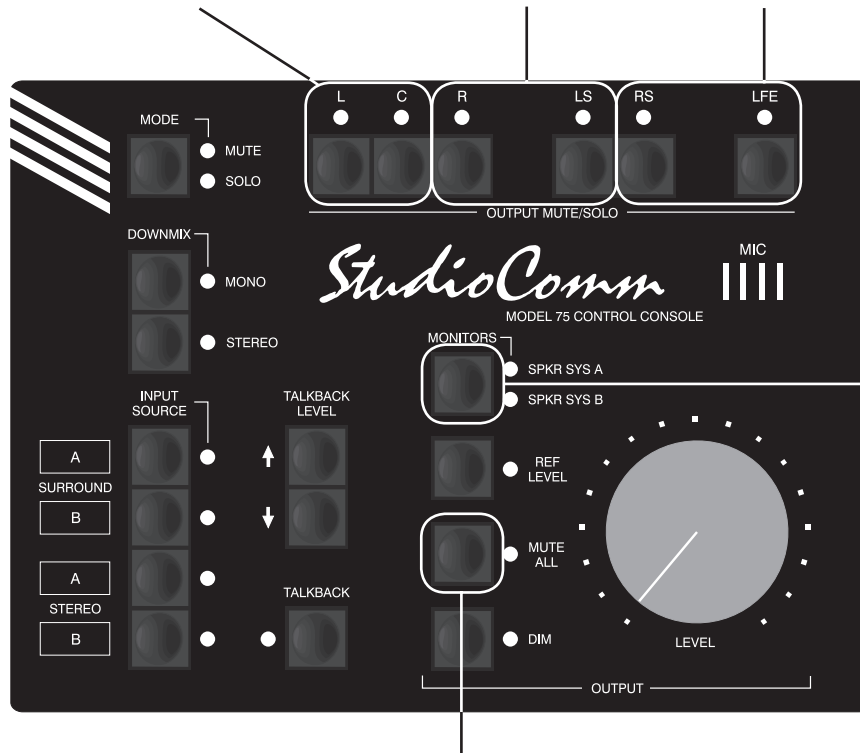

Press and hold the Speaker System A/B button to display and select the status of the solo mode, power-up mute all function, level control response mode, and level control auto mute all function.

Press and hold the Speaker System A/B button to display and select the status of the level control auto mute all function. When the LED is lit the function is enabled. Use the button to change the configuration.

Default: Additive solo mode enabled.
Upon power up, mute all function enabled.
Level control provides modified logarithmic response.
Level control auto mute all function enabled.

Model 75 Configuration—Reference Level

 Press and hold the Ref button for five seconds to take a “snapshot” of the level control’s present setting. The Ref LED will light when the “snapshot” has been taken.

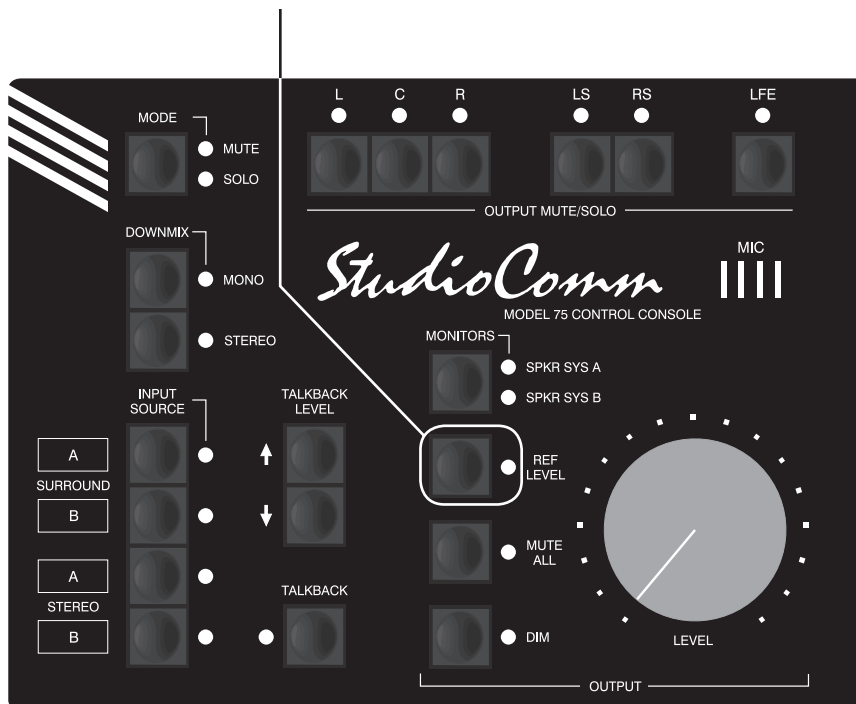

Default: Fully attenuated (minimum) monitor output level.

Note: The 5-second delay is a safety feature, ensuring that the reference level will not be accidentally changed. To permanently store the new value, you must still exit the configuration mode.

Model 75 Configuration—Remote Input Select

These LEDs display the mode of the remote input select function. LED L lit means that the function is disabled. LED C lit means that the function provides exclusive input select. LED R lit means that the function provides non-exclusive input select. Use the buttons to change the configuration.

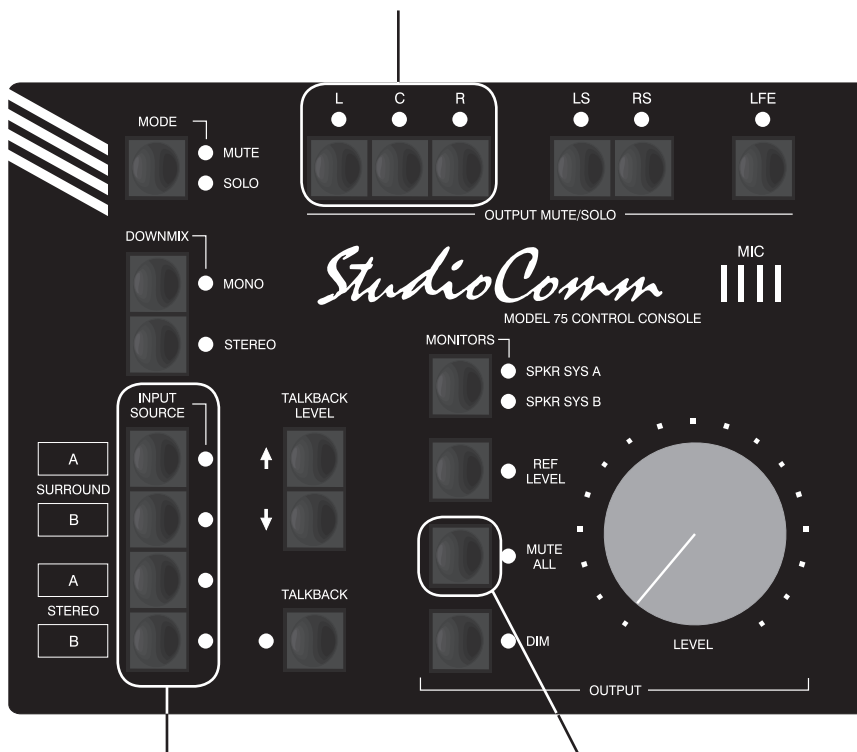

When the Mute All button is pressed, these LEDs display the input associated with the remote input select function:

LED Surround A lit means Surround A;
LED Surround B lit means Surround B;
LED Stereo A lit means Stereo A;
LED Stereo B lit means Stereo B.

Use the buttons to select the input.



Press and hold the Mute All button to display and configure the remote input select function.

Default: Remote input select function disabled.
Surround A associated with remote input select function.

Model 75 Configuration—Dim Level, Remote Mute All, Remote Dim, Remote Talkback, Auto Dim Off, and Talkback Dim

These LEDs display the configuration of remote mute all. LED L lit means that remote mute all is disabled; LED C lit means enabled. Use the buttons to change the configuration.

These LEDs display the configuration of remote dim. LED R lit means that remote dim is disabled; LED LS lit means enabled. Use the buttons to change the configuration.

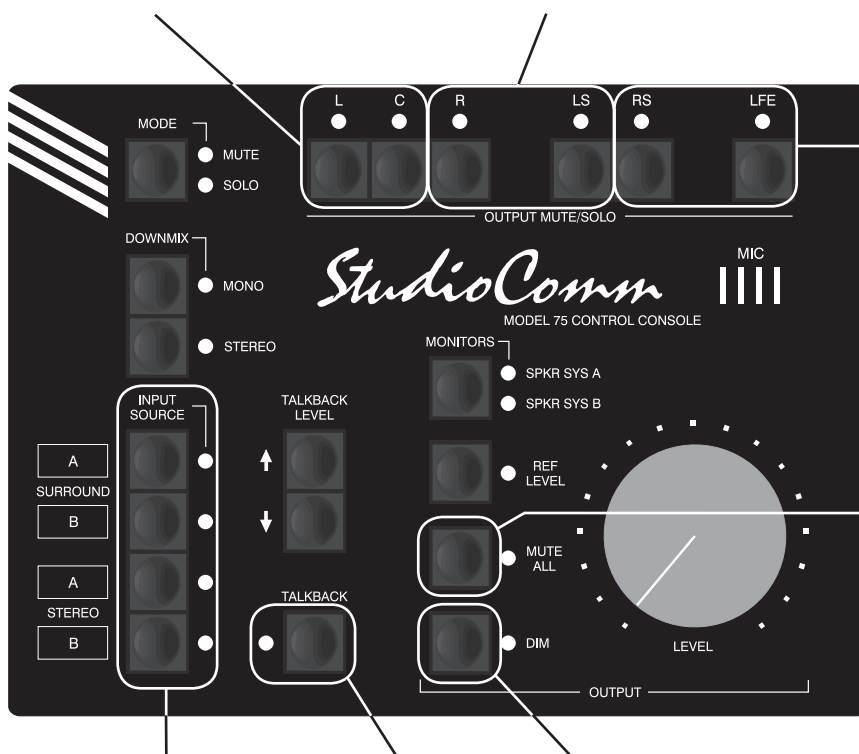

These LEDs display the status of the remote talkback inputs (hard-wired and IR). LED RS lit means that the inputs are disabled; LED LFE lit means the inputs are enabled. Use the buttons to change the configuration.

Press Mute All to toggle the automatic dim off function; LED on means auto dim off function is active.

When the Dim button is pressed, these LEDs display the selected dim level:

LED Surround A lit means 25 dB dim;
LED Surround B lit means 20 dB dim;
LED Stereo A lit means 15 dB dim;
LED Stereo B lit means 10 dB dim.

Use the buttons to select the dim level.



Press and hold the Dim button to display and select the dim level, remote mute all, remote dim, talkback remote input, and auto and talkback dim off configurations.

Press the Talkback button to toggle the talkback dim function; LED on means talkback dim function is active.

- Default:** 20 dB dim level.
Remote mute all disabled.
Remote dim disabled.
Remote talkback inputs (hard-wired and IR) disabled.
Auto dim off enabled.
Talkback dim enabled.

Model 75 Configuration—Stereo to Mono Downmix

 Press and hold the Mono button to display and configure the stereo to mono downmix mode, whether 5.1 to stereo downmix is automatically activated when stereo to mono downmix is activated, and the attenuation level when mono is active.

When the Mono button is pressed, these LEDs display the mode of the stereo to mono downmix function. When LED L is lit the mono-to-left-and-right mode is selected. When LED C is lit the mono-to-center mode is selected. Use the buttons to change the configuration.

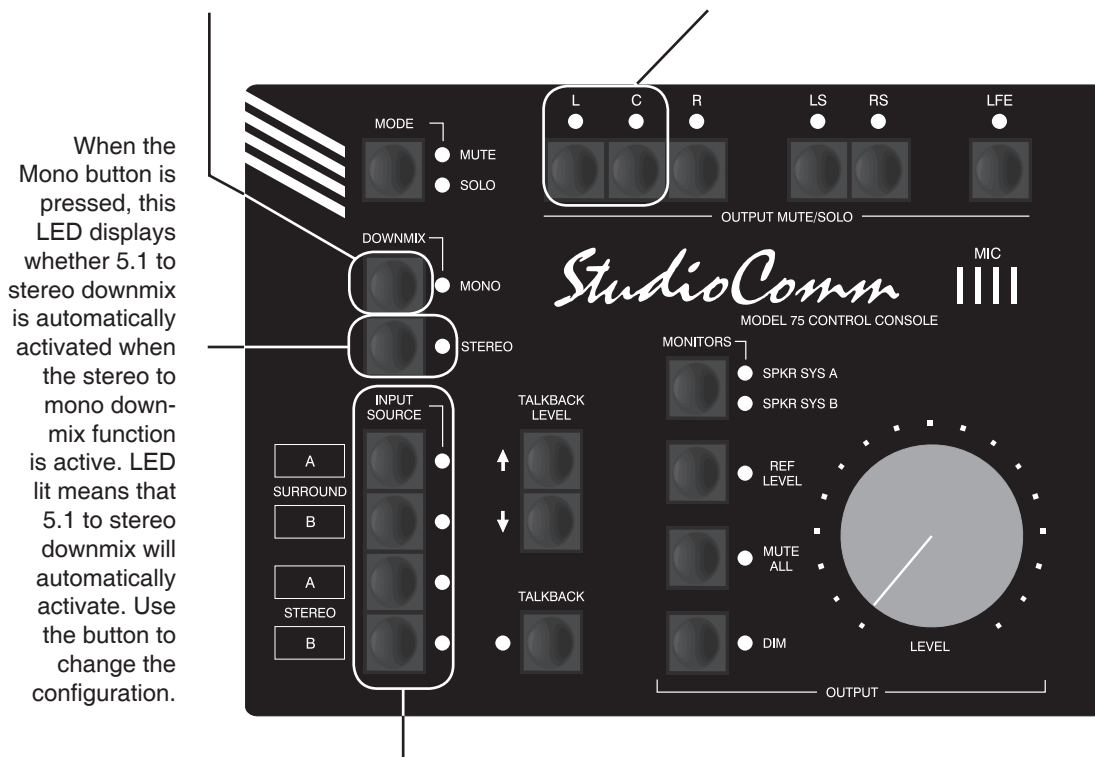

When the Mono button is pressed, these LEDs display the attenuation level when mono-to-center is active:

LED Surround A lit means 6 dB;

LED Surround B lit means 4 dB;

LED Stereo A lit means 3 dB;

LED Stereo B lit means 0 dB.

Use the buttons to select the attenuation level.

Default: Stereo to mono downmix mode: mono-to-center.
3 dB attenuation when mono-to-center is active.
5.1 to stereo downmix automatically activated when stereo to mono downmix activated.

Model 75 Configuration—Restore Factory Defaults

 Press and hold both Surround A and Stereo B buttons for five seconds to restore Model 75 factory defaults. Once defaults have been restored, the LEDs will light. After buttons are released, configuration mode will be exited and normal operation will resume.

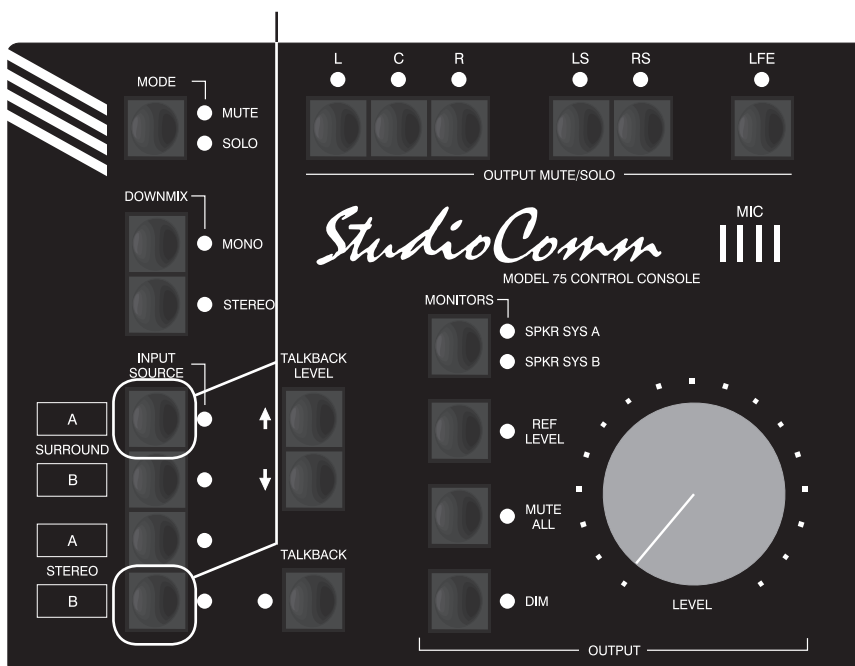

Factory Defaults: All channels associated with each input are active.
 Speaker system A all six channels are assigned to output A only.
 Speaker system B all six channels are assigned to output B only.
 Talkback button is set for momentary operation.
 Talkback adds to cue audio mode enabled.
 Talkback audio source is Model 75 mic.
 Cue program audio enabled.
 Additive solo mode enabled.
 Upon power up, mute all function enabled.
 Level control operates modified logarithmic.
 Level control auto mute all function enabled.
 Reference level is set for fully attenuated (minimum) monitor output level.
 Remote input select function disabled.
 Surround A associated with remote input select function.
 20 dB dim level.
 Remote mute all disabled.
 Remote dim disabled.
 Remote talkback inputs (hard-wired and IR) disabled.
 Auto dim off enabled.
 Talkback dim enabled.
 Stereo to mono downmix mode: mono-to-center.
 3 dB attenuation when mono-to-center is active.
 5.1 to stereo downmix automatically activated when stereo to mono downmix activated.

Note: The 5-second delay is a safety feature, ensuring that the factory defaults will not be accidentally restored.

Operation

Now that you've installed and configured the system, you're ready to go. You should find operation very easy.

Model 74 Central Controller

The Model 74's front panel contains two LEDs. The power LED should be lit whenever AC mains power is connected. The data LED will light whenever a MIDI system-exclusive message is received from the Model 75.

Model 75 Control Console

StudioComm operation is controlled using the Model 75 Control Console and, if connected, the remote control inputs. To make things easy to describe, we've divided the StudioComm functions into six main groups: input source selection, downmix, monitor output functions, mute/solo, headphone cue system/talkback, and remote controls.

Input Source Selection

Input source selection is simple. To select an input source for routing to the monitor outputs, press one of the four input source buttons. The corresponding LED will light to let you know that the input has been selected. You can select more than one input source simultaneously; up to all four. The selected inputs will be summed (combined). Start by pressing and holding the button associated with the first desired input source. While the button is still pressed, add the extra inputs by momentarily pressing the buttons associated with them. The LEDs will light to tell you which inputs have been selected.

A recall feature is an integral part of the input selection process. It's a bit confusing to explain, but simple once you experience it in "real time." A one-sentence explanation would describe the input recall feature as allowing the system to return to the previously selected input (or inputs) by simply pressing one button. It was included specifically for film-post applications where it's important to be able to change quickly between a combination of inputs, such as two "stems," and a single input.

Let's begin the explanation with an example: A film-post facility where the usual monitoring setup has both Surround A and Surround B simultaneously selected, while Stereo A is occasionally selected to monitor a cue track. To select both inputs, press and hold the button associated with Surround A, then press Surround B's button, then release both buttons. Surround A and B are now selected for monitoring. To monitor Stereo A press the button associated with it. To return to monitoring Surround A and B, simply press Stereo A's button again. The recall feature has returned the system to the previously selected inputs. That's all there is to it!

A special configuration mode allows an input to be disabled. This would be appropriate if an input is not connected to an audio source. If you press an input source button and the previously selected input source does not change, the newly selected input has been disabled.

Downmix

Two downmix functions allow an operator to perform "real-world" compatibility checks. They can also be referred to as format functions because they allow conversion between various audio formats, e.g., 5.1 (surround) signals converted

to stereo or stereo signals converted to mono. How these functions affect the audio signals will greatly depend on how the Model 75 is configured. Being aware of the selected configuration will allow the functions to serve a more useful role.

5.1 to Stereo

The 5.1 to stereo downmix function allows surround signals to be mixed or “folded down” into a stereo (left and right) signal. Phase relationships and inter-channel level issues can be quickly observed. Please refer to the Technical Notes section of this guide for a detailed description of how the 5.1 to stereo function mixes the surround sources to stereo.

Using the 5.1 to stereo function simply requires the button labeled Downmix Stereo to be pressed. The button is always set to “latch” the function on and off. The associated LED lights when the function is enabled. The stereo signal created by the 5.1 to stereo downmix function is routed to the left and right channels of the selected monitor output.

Depending on how the Model 75 Control Console is configured, the 5.1 to stereo downmix function may automatically enable whenever the stereo to mono downmix function is enabled. This is provided to ensure an operator hears a valid mono signal when a surround source is selected as an input.

Stereo to Mono

The operating characteristics of the stereo to mono downmix function depend on the Model 75 Control Console’s configuration. Two stereo to mono downmix modes are available, as are four attenuation levels. In the mono-to-left-and-right mode the function combines (sums) the signals on

the left and right channels and routes the result to both the left and right channels of the selected monitor output. This method is the same as found on many stereo-oriented audio consoles. Useful for music mixing, it’s not true monaural but rather binaural.

The mono-to-center mode of the stereo to mono downmix function combines (sums) the left and right channels and routes the result to the center channel of the selected monitor output. This function allows a more accurate reproduction of a mono signal, but may not be suitable for all operators.

To enable the stereo to mono downmix function simply requires the button labeled Downmix Mono to be pressed. The button is always set to “latch” the function on and off. The associated LED will light whenever the function is enabled.

Bandpass Filter for Mono-to-Center Mode

A special feature has been included to assist an operator in determining compatibility with “real-world” playback environments. A bandpass filter can be inserted into the path of the stereo to mono downmix signal when it is being routed to the center channel. This allows the simulation of the response of a loudspeaker associated with an inexpensive monaural television or portable radio. The filter passes signals in the range of 100 Hz to 5 kHz, while rejecting those above and below.

To highlight for clarity, the bandpass filter is only available for use when the stereo to mono downmix function has been configured for the mono-to-center mode. For a detailed technical description of the bandpass filter please refer to the Technical Notes section of this guide.

To enable the bandpass filter feature requires knowing a “secret” button push method. But it’s not much of a secret, as you simply press and hold the downmix mono button for two seconds to enable the function. From that point forward, whenever the stereo to mono downmix function is enabled the bandpass filter will also be enabled. To indicate that the bandpass filter is enabled, the LED associated with the downmix mono button will flash whenever its associated function is enabled. To disable the bandpass function, press and hold the downmix mono button for two seconds. The change will be indicated by the LED, which will now light steadily whenever the stereo to mono downmix function is enabled.

Monitor Output Functions

Four buttons and one rotary control are associated with the monitor output functions. The buttons control operation of the speaker system selection, reference level, mute all, and dim. The rotary level control is used to manually set the monitor output level.

Speaker Systems

One button allows selection between speaker system A and speaker system B. There are two LEDs associated with the function, providing a visual display of the active system. It’s important to remember that the performance of the speaker systems is installation specific. Using the Model 75’s configuration choices, the monitor output channels associated with speaker system A and speaker system B are selected.

Note that the Model 75 Control Console can be configured to disable either of the monitor outputs. If the monitor button is pressed and nothing happens, this must be the case!

Reference Level

The reference level button, labeled Ref Level, sets the monitor output level to a preset value. This level is normally set by a technician, using a sound pressure level (SPL) meter, at the time of system installation. The LED associated with the reference level function lights whenever the function is active. Whenever reference level mode is active the rotary level control is disabled.

The reference level LED also serves as a calibration aid. If the reference level mode is not active and the rotary level control is set at precisely the same level as that stored for the reference value, the reference level LED will flash.

Mute All

The mute all function is highly complicated to operate—not! Pressing the mute all button causes the monitor outputs to mute. The mute all button is always set to “latch” the function on and off. The LED associated with the mute all button will light whenever mute all is active. Note that if mute all is enabled via the remote mute all function, the mute all LED will flash.

Dim

The dim function is quite self-explanatory. Press the dim button to enable the dim mode, which reduces the monitor output level by a preset amount. The dim button is always set to “latch” the function on and off. Dim activity applies no matter whether the monitor output level is being set by the rotary control or the reference button. The dim level can be configured for 10, 15, 20, or 25 dB, so one of those values will apply when dim is active. The LED associated with the dim button will light whenever dim is active.

Other functions can also cause the dim function to enable. Depending on how the Model 75 is configured, it may also enable whenever the talkback function is active. The remote dim function allows a hard-wired control signal to enable dim. If dim is enabled via remote dim, the dim LED will flash.

If the auto dim off function is enabled, whenever dim is on and the rotary level control is changed, dim will automatically return to the off state. However, auto dim off will not occur if the rotary control is changed while either the talkback or remote dim functions are active. This ensures that the talkback function and the external equipment controlling the remote dim input will function appropriately.

Rotary Level Control

The rotary level control is used to manually adjust the monitor output level. It is active any time the reference level function is not active. When the rotary level control is set to give the same output level as the preset reference level, the reference level LED will flash.

By default, when the rotary level control is set to its fully counterclockwise position, the monitor output channels automatically mute. This feature is provided for those users accustomed to having a completely quiet output when the level control is set to its minimum position.

A Model 75 configuration parameter allows the level control's automatic mute all function to be disabled. When disabled, the rotary level control simply adjusts the monitor output level over its approximately 72 dB of range. When the control is in its fully counterclockwise position, low level

audio signals can be present on the monitor outputs. This level control operating mode may be preferable for those users who do not like the abrupt level change that occurs when the automatic mute all function activates. When the automatic mute all function is disabled, the mute all button can be used to achieve a full monitor output mute.

Mute/Solo

The mute/solo mode button and the six monitor output channel buttons, along with associated LEDs, work together to provide excellent operating flexibility. The mute/solo mode switch allows the operator to select between mute and solo functions. Going from mute mode to solo mode, or vice-versa, clears all active mutes or solos. Pressing the mode switch twice is a legitimate means of quickly clearing muted or soloed channels.

In the mute mode, multiple channels can be muted simultaneously. A channel that is muted has its associated LED turned on. The solo mode can operate in one of two ways: additive or exclusive. How solo operates follows the configuration set in the Model 75 Control Console. In additive solo mode, multiple channels can be soloed simultaneously. A channel that is soloed has its associated LED flash on and off, while the LEDs on the non-soloed channels are not lit.

As expected, in the exclusive solo mode pressing a channel button will cause that channel to be soloed. But, in addition, any other channel or channels being soloed will go back to their normal, non-solo condition. Thus the exclusive solo mode allows rapid "soloing" of individual channels. Should more than one channel need to be simultaneously soloed, simply push

and hold a channel button, then add the extra channels by momentarily pressing their buttons.

Headphone Cue System/Talkback

The headphone cue system and its associated talkback function is simple to use, but does offer a number of user and configuration options. On the Model 75, three buttons and one LED are used to control these functions.

The talkback button on the Model 75 is used to enable the talkback function. Depending on the Model 75's configuration, the button may provide a push-to-talk or a latching (push on/push off) action. In most cases enabling the talkback function will also cause the dim function to enable. However, be aware that a Model 75 configuration does allow talkback to not enable dim. The LED associated with the talkback button will light whenever talkback is enabled using the button on the Model 75. Remotely enabling talkback, using a hard-wired connection or an infrared (IR) source, will cause the talkback LED to flash.

By using the two talkback level buttons, the talkback level can be selected over an 8-step range. To adjust the talkback level, enable the talkback function and press the up or down button as required. The LED associated with the talkback button will flash each time the level is increased or decreased until the top or bottom of the range is reached. At this point, if you continue to press the same level button the LED won't flash, indicating you're at the top or bottom of the 8-step level range.

Depending on how the talkback function has been configured, talkback audio will either add to (sum with) the selected cue audio source or it will replace (interrupt)

the source. Note that it's also possible to configure the system so that no cue audio source will be present at any time.

A "hidden" Model 75 function allows the cue audio source to be selected from between two choices. The first choice is the left and right audio channels being sent to the monitor outputs. These channels are post (after) the input source buttons and the downmix functions; whatever is being heard out of the left and right monitor loudspeakers will be heard in the headphone cue system. The second cue audio choice is Stereo B. If this choice is selected, the source or sources selected for the monitor outputs will have no impact on what is heard in the headphone cue system.

It's a simple matter to determine which cue audio source is selected and, if desired, change to the other one. When the talkback function is not active, press both the talkback level up and level down buttons. The four input source LEDs will no longer reflect the selected monitor source (or sources) but instead will display the selected cue audio source. Observing the LED associated with Stereo B, if it is not lit the cue audio source is the left and right channels being sent to the monitor outputs. If the LED associated with Stereo B is flashing, the cue audio source is Stereo B. To change the selected cue audio source, press the Stereo B button.

Note that the Model 75 doesn't provide an overall level adjustment for the cue audio and talkback output signals that are sent to the talent amplifier and line-level cue outputs. As was previously discussed, the relative level of the talkback audio versus the cue audio can be adjusted. This reflects the StudioComm's system architecture and isn't a design deficiency. The overall level

for a pair of headphones connected to a Model 35 Talent Amplifier is adjusted using the Model 35's level control. A headphone cue system connected to the Model 74's line-level cue output must have its own level controls.

Remote Controls

Four hard-wired remote control signals can be connected to the system and configured for the desired operating characteristics: mute all, dim, talkback, and input select. In addition, an infrared (IR) receiver can be connected to allow wireless activation of the talkback function.

When remote mute all is activated the LED on the Model 75 associated with mute all will flash. If mute all was already active when the remote mute all function is activated, the LED will change from being steadily lit to flashing.

When remote dim is activated the LED on the Model 75 associated with the dim function will flash. If dim was already active when remote dim is activated, the LED will change from being steadily lit to flashing.

When remote talkback is activated, either via a hard-wired connection or an infrared (IR) signal, the LED on the Model 75 associated with the talkback function will flash. If dim was already active when remote talkback is activated, the LED will change from being steadily lit to flashing.

When remote input select is activated, the LED on the Model 75 associated with the selected input will flash. If the function is set for exclusive, no other LEDs will be lit. If the function is set for non-exclusive, the LED associated with remote input select will flash, while the LEDs associated with any other active inputs will remain steadily lit.

Model 35 Talent Amplifier

Up to four Model 35 Talent Amplifiers can be connected to a Model 74. The power present LED on each Model 35 should be lit whenever it's connected to a powered-up Model 74. The user is provided with a rotary level control, stereo/mono button, and two ¼-inch 3-conductor (stereo) headphone jacks. One or two pairs of headphones with a total impedance of 75 ohms or greater can be connected. Adjust the control to achieve the desired output level. To highlight, the headphone output level is only adjusted using the Model 35's rotary control; there are no headphone level adjustments available on the Model 75. Using the button the output can be selected for stereo or mono. When selected for mono, the left and right channels are combined (summed) and routed to both the left and right outputs.

Warning: Protect your ears! The Model 35 Talent Amplifier is capable of driving headphones to extremely high sound pressure levels. Hearing experts advise against continuous extended play, especially at high levels.

Technical Notes

Downmix

The downmix functions are implemented in the Model 74 Central Controller's hardware using analog circuitry. From the factory 5.1 to stereo downmix is defined as: center dropped in level by 6 dB and routed to left and right; left surround dropped in level by 3 dB and routed to left; right surround dropped in level by 3 dB and routed

to right; LFE muted. By making simple resistor changes the level changes can be easily revised. In addition, provision has been made to allow the LFE signal to be routed to the left and right channels during downmix.

While no soldering is required, a competent technician is required to perform any changes to the downmix function. This will help to ensure a safe and successful modification. Page 5 of the Model 74 schematic contains the circuitry that implements the downmix function. Please contact the factory for a copy of the schematic.

Bandpass Filter

The bandpass filter associated with the mono-to-center downmix mode is created by cascading (connecting in series) a high-pass and a low-pass active filter. Each filter is a Sallen-Key type, with a 12 dB-per-octave response. The high-pass filter has a nominal -3 dB point at 100 Hz; the low-pass at 5 kHz. For a detailed description of the filters, refer to page 5 of the Model 74 schematic diagram.

High-Pass Filter

Components were selected at the factory so that the high-pass filter section's output has a -3 dB point of nominally 100 Hz. (To be more precise, the math calculations work out to be 102 Hz.) For some applications it may be optimal to adjust this frequency. The Model 74 makes this a simple task, with no soldering or complicated procedures required. Refer to page 5 of the schematic for details.

The frequency of the high-pass filter is configured by means of three resistors, each identical in value. A 6-position socket, located on the Model 74's printed circuit

board, is used to hold the resistors. As received from the factory, one 22 k ohm 6-pin single-inline-package (SIP) resistor is used to configure the filter for nominally 100 Hz. To revise the high-pass frequency this SIP resistor can be replaced. The SIP resistor must be an isolated-terminal-type, providing three independent resistors in one assembly. Alternately, using $\frac{1}{4}$ -watt 1%-tolerance resistors is appropriate.

A simple formula is used to determine the resistance required for a specific filter frequency: $R = 2,250,000 \div F$, where R is resistance in ohms and F is frequency in hertz.

Low-Pass Filter

Components were selected at the factory so that the low-pass filter section's output has a -3 dB point of nominally 5 kHz. (To be more precise, the math calculations work out to be 5.25 kHz.)

The frequency of the low-pass filter is configured by means of two $\frac{1}{4}$ -watt, 1%-tolerance resistors, each identical in value. One 6-pin socket, located on the Model 74's printed circuit board, is used to hold the resistors. From the factory, two 14.3 k ohm resistors configure the filter for nominally 5 kHz. One resistor is inserted into socket pins 1 and 2, the second into pins 3 and 4. To revise the frequency, these can be replaced with two other resistors, or one 6-pin SIP resistor package. It's important to note that the SIP resistor must be an isolated-terminal-type, providing three independent resistors in one assembly. For details refer to page 5 of the Model 74 schematic diagram.

A simple formula is used to determine the resistance required for a specific filter frequency: $R = 75,000,000 \div F$, where R is resistance in ohms and F is frequency in hertz.

Monitor Output Gain Structure

The Model 74 Central Controller's monitor outputs are configured for unity gain. When the rotary level control on the Model 75 Control Console is set for maximum level (fully clockwise) the output level is essentially the same as the input level. The input trim potentiometers allow precise adjustment of the input circuitry. This was provided so that level variations in input sources, the Model 74's circuitry, and the associated power amplifiers can be "trimmed out."

Definition of Levels

Whenever possible, when describing audio signal levels Studio Technologies has opted to use the dBu designation as it seems to be quite rational. The dBu designation refers to dB referenced to 0.775 V, with no reference to load impedance. This takes into account today's audio scene where signals have a low source impedance and a high input impedance.

The Model 74 is designed to interface with audio signals that have nominal signal levels of -12 dBV to +6 dBu. You might wonder why "dBV" came into the picture. Most people don't realize that equipment that utilizes "-10" levels usually mean -10 dBV—substantially different from -10 dBu (-10 dBV = -7.78 dBu). The dBV designation is simply a different way of measuring signal level and is often used when dealing with portable or consumer

audio equipment. The dBV designation refers to dB referenced to 1.0 V, rather than dBu which refers to 0.775 V.

"Hot" Disconnection of the Model 75 Control Console

Should you need to relocate the Model 75 while your StudioComm system is operating, there is no reason why you can't disconnect the cable, move the unit, and then reconnect the cable. If the Model 75 is disconnected while it is operating, the active operating parameters are saved in nonvolatile memory and the Model 74 Central Controller will continue to operate as before the connection was broken. No clicks, pops, or other noises will occur when the Model 75 is again connected. The Model 75 will go through its standard power-up sequence, send a message to reset power-up defaults, then send the operating parameters as are stored in its memory. Depending on its configuration settings vis-à-vis power-up, the Model 74's monitor outputs may be placed in their mute mode.

Monitor Output Transient Protection

The Model 74 Central Controller contains a power up/power down protection feature. This limits the chance of damage to the monitor loudspeakers during the time when AC mains voltage is connected, disconnected, or has dropped significantly from nominal. During testing it was found that upon power up the monitor outputs remained very quiet; during power down a moderate "tick" was the worst that was heard. A combination of hardware and software is used to monitor one "rail" of the internal power supply. Upon initial

connection of AC mains power electro-mechanical relays maintain a short circuit condition on the monitor outputs. If the AC mains input voltage exceeds 90% of nominal for approximately four seconds the relays are allowed to function normally. Whenever the AC mains input voltage drops below approximately 85% of nominal the relays immediately go to their mute state. The Model 74 will stay in this low-voltage state until the AC mains voltage has again exceeded 90% of nominal for approximately four seconds. Any time the Model 74 is in the low-voltage state the power LED, located on the front panel, will flash.

Mono-to-Center Polarity

It's worthwhile to note that a polarity inversion takes place whenever the stereo to mono downmix's mono-to-center function is active. By design, the input signals experience a 180-degree inversion in the Model 74's mono-to-center combining circuitry. This should not cause a problem as monitoring audio signals over a single loudspeaker is considered polarity insensitive. Only during electrical testing would this condition be detected.

Talent Amplifier Cable Length

There are no hard and fast rules defining the maximum cable length when connecting Model 35 Talent Amplifiers to the Model 74 Central Controller. The maximum cable length is directly related to the amount of resistance in the connecting cable; the lower the resistance per foot (or meter), the longer the cable can be. (Although cable capacitance affects high frequency performance, resistance is the limiting factor in this case.)

To lay out the facts in grammar-school story problem format: for correct operation, a Model 35 needs to see at least 20 volts DC between pins 1 and 2 of their input connector. The Model 74's talent amplifier output voltage across pins 1 and 2 is 27 volts DC, with a maximum current draw of 200 milliamperes. This difference between the voltage supplied and the voltage required results in a maximum voltage drop of 7 volts over the interconnecting cables. Since cable is rated in ohms per 1000 feet (or ohms per 1000 meters), you need to know what the maximum cable resistance is. This can be easily calculated by dividing the maximum voltage drop by the maximum current flow: 7 volts divided by 200 milliamperes (0.2 A) = 35 ohms. For example, a standard 20 AWG microphone cable is Belden 8412, which has 10.9 ohms resistance per conductor per 1000 feet. Since we're using two conductors to carry the signal (pins 1 and 2) you'd get 21.8 ohms per 1000 feet of microphone cable. With our 35 ohm maximum resistance you'd be able to use 1600 feet (492 meters) of this cable.

By using the numbers provided you can select a cable, and its maximum length, for your application.

Model 74 to Model 75 Connections

Figure 11 gives a detailed view of the signals that connect between the Model 74 Central Controller and the Model 75 Control Console. The Model 74 provides +15 volt DC power for the Model 75. The Model 75 generates MIDI system-exclusive messages and sends them to the Model 74. From the outside world, the four hard-wired remote control input

sources connect to the Model 74. They then route, via the interface cable, from the Model 74 to the actual input circuitry, located in the Model 75.

It should be noted that the infrared (IR) remote talkback circuit “tags along” with the hard-wired remote talkback input. An IR receiver module connects via input circuitry to the Model 74’s microcontroller integrated circuit. Under software control IR-generated requests for talkback are decoded. A logic output pin on the microcontroller goes to logic high (+5 volts DC) whenever talkback is detected. This signal drives the input of an optocoupler integrated circuit. The optocoupler’s output transistor is connected directly across pin 7 (remote talkback) and pin 9 (ground) on the two 9-pin D-subminiature connectors. In this way the IR talkback input is “OR’d” (connected in parallel) with the hard-wired remote talkback input. The signal reaches the Model 75 Control Console where it performs the talkback function. The Model 75 doesn’t have the logic to recognize a remote talkback signal that is generated by a hard-wired connection or a IR request.

Spare Remote Control Inputs

Figure 10 lists two spare (unused) remote control inputs. These inputs are provided for future special applications. It’s interesting to note that they are quite unlike the four hard-wired remote control inputs. Inside the Model 74, the four hard-wired remote control inputs are directly routed to the connector that links to the Model 75 Control Console. The microcontroller in the Model 75 monitors and acts upon those four signals. The two spare inputs stay

within the Model 74, connecting to input ports on the Model 74’s microcontroller; they do not connect to the Model 75. Inside the Model 74 these spare inputs are “pulled” to logic high (5 volts) and ESD-protected prior to connecting to the Model 74’s microcontrollers.

Specifications

Model 74 Central Controller

General Audio:

Frequency Response: 20 Hz-20 kHz \pm 0.1 dB (down 0.5 dB @ 60 kHz), monitor outputs

Distortion (THD+N): 0.04%, measured at 1 kHz, +4 dBu, monitor outputs

S/N Ratio: 87 dB, ref +4 dBu out, 20 Hz-20 kHz, monitor outputs

Crosstalk: 78 dB, typical, ref +4 dBu in, 20 Hz-20 kHz, monitor outputs

Audio Inputs: 16, organized as two 6-channel "5.1" inputs and two 2-channel "stereo" inputs

Type: electronically balanced, compatible with balanced or unbalanced sources

Impedance: 24 k ohms

Nominal Level: -12 dBV to +6 dBu, adjustable

Level Calibration: 15-turn trim potentiometers

Monitor Outputs: 2, 6-channel

Type: electronically balanced, compatible with balanced or unbalanced loads

Maximum Level: +27 dBu into 10 k ohms, +26 dBu into 600 ohms

Talent Amplifier Output:

Compatibility: provides power and audio signals for up to four Model 35 Talent Amplifiers

Type: DC power with two channels of unbalanced audio

Connections: common on pin 1, DC (+27 volts nominal, 200 milliamperes maximum) modulated with channel 1 audio (-10 dBu nominal) on pin 2, and channel 2 audio (-10 dBu nominal) on pin 3

Line-Level Cue Output: 1, stereo

Nominal Level: +4 dBu, nominal

Type: electronically balanced, capacitor-coupled, intended to drive balanced or unbalanced loads of 600 ohms or greater

Source Impedance: 100 ohms, nominal

Maximum Level: +20 dBu into 10 k ohms

Line-Level Talkback Input:

Level: +4 dBu, nominal

Type: electronically balanced

Impedance: 24 k ohms, nominal

Infrared Receiver Input:

Type: intended for use with industry-standard receiver module; data rate 650 baud

Remote Control Inputs: 4

Type: +5 volts DC logic, activates on closure to system common

Functions: mute, dim, talkback, input select

Downmix:

Functions: 5.1 to stereo, stereo to mono (mono-to-left-and-right, mono-to-center)

5.1 to Stereo: LS @ -3 dB summed with L; RS @ -3 dB summed with R, C @ -6 dB summed with L and R; LS, RS, and LFE monitor outputs mute

Stereo to Mono (Mono-to-Left-and-Right): L summed with R to L and R or L summed with R to C; attenuation independently configurable; C, LS, RS, and LFE monitor outputs mute

Stereo to Mono (Mono-to-Center): L summed with R to C; attenuation independently configurable; L, R, LS, RS, and LFE monitor outputs mute

Stereo to Mono (Mono-to-Center) Bandpass Filter:

Response: -3 dB @ 100 Hz and 5 kHz, nominal, 12 dB/octave

Connectors:

Audio: 4, 25-pin D-subminiature female

Talent Amplifier Output: 3-pin male XLR-type

To/From Model 75: 9-pin D-subminiature female

Remote Control Inputs: 9-pin D-subminiature female

Infrared Receiver Input: 3.5 mm 3-conductor jack

AC Mains: 3-blade, IEC 320 C14-compatible (mates with IEC 320 C13)

AC Mains Requirement:

100, 120, or 220/240 V, \pm 10%, factory configured, 50/60 Hz, 26 watts maximum

Dimensions (Overall):

19.00 inches wide (48.3 cm)
1.72 inches high (4.4 cm)
9.58 inches deep (24.3 cm)

Mounting: one space in a standard 19-inch rack

Weight: 9.5 pounds (4.3 kg)

Model 75 Control Console

Application: supports Model 74 Central Controller

Power: provided by Model 74 Central Controller

Output Data: generates MIDI system-exclusive messages

Connector: 9-pin D-subminiature female

Dimensions (Overall):

7.2 inches wide (18.3 cm)
2.2 inches high (5.6 cm)
5.4 inches deep (13.7 cm)

Weight: 1.8 pounds (0.82 kg)

Model 35 Talent Amplifier

Load: intended for connection to one or two pairs of headphones with total impedance of 75 ohms or greater

Maximum Output Voltage: 16 V peak-to-peak into 150 ohms @ 1% THD+Noise

Distortion (THD+N): 0.03%

Frequency Response: 20 Hz-20 kHz \pm 0.5 dB

Dimensions (Overall):

4.2 inches wide (10.7 cm)
2.0 inches high (5.1 cm)
5.3 inches deep (13.5 cm)

Weight: 0.8 pounds (0.7 kg)

Specifications and information contained in this User Guide subject to change without notice.

Appendix A

Controlling the Model 74

The Model 74 Central Controller uses MIDI system-exclusive messages to control all functions. The Model 75 Control Console is programmed to generate a subset of what the Model 74 is capable of doing. By using standard MIDI messages, the Model 74 can be used for a wide range of special applications. Any device that can be programmed to send system-exclusive MIDI messages can be used to control the Model 74.

General Notes:

All MIDI messages to be acted upon are system-exclusive type (F0H). No channel mode, system common, or system real time messages are utilized.

Studio Technologies, Inc. manufacturer's ID number is 00H 00H 56H.

The Model 74's product device ID number is 07H.

Function: Reset to Power Up Default Configuration

Byte	Value	Description
1	F0H	System-Exclusive Message
2	00H	1 st Byte of Studio Tech ID
3	00H	2 nd Byte of Studio Tech ID
4	56H	3 rd Byte of Studio Tech ID
5	07H	Product ID (Model 74)
6	00H	Function, Restore Power Up Default Configuration
7	F7H	EOX, End of System-Exclusive Message

Notes: Action taken after message is received:
Set all input sources to off.
Set all monitor output channels to off.
Set monitor output level to minimum.
Set stereo to mono downmix function to off.
Set 5.1 to stereo downmix function to off.

Function: Input Source and Associated Channels

Byte	Value	Description
1	F0H	System-Exclusive Message
2	00H	1 st Byte of Studio Tech ID
3	00H	2 nd Byte of Studio Tech ID
4	56H	3 rd Byte of Studio Tech ID
5	07H	Product ID (Model 74)
6	01H	Function, Input Source and Associated Channels
7	0nH	Input Source, range 1-4: 1=Surround A 2=Surround B 3=Stereo A 4=Stereo B
8	nnH	Input Channel Status Bit Map (sum values from all six channels): Channel 1 (L): off=00; on=01 Channel 2 (R): off=00; on=02 Channel 3 (C): off=00; on=04 Channel 4 (LFE): off=00; on=08 Channel 5 (LS): off=00; on=10 Channel 6 (RS): off=00; on=20
9	F7H	EOX, End of System-Exclusive Message

Note: Inputs 3 and 4 only have input channels 1 (L) and 2 (R) associated with them. Channels 3 (C), 4 (LFE), 5 (LS), and 6 (RS) are not physically present on inputs 3 and 4.

Function: Monitor Output Channel Status

Byte	Value	Description
1	F0H	System-Exclusive Message
2	00H	1 st Byte of Studio Tech ID
3	00H	2 nd Byte of Studio Tech ID
4	56H	3 rd Byte of Studio Tech ID
5	07H	Product ID (Model 74)
6	02H	Function, Monitor Output Channel Status
7	nnH	Monitor Output A Channel Status using Output Relays Bit Map (sum values from all six channels): Channel 1 (L): off=00; on=01 Channel 2 (R): off=00; on=02 Channel 3 (C): off=00; on=04 Channel 4 (LFE): off=00; on=08 Channel 5 (LS): off=00; on=10 Channel 6 (RS): off=00; on=20
8	nnH	Monitor Output B Channel Status using Output Relays Bit Map (sum values from all six channels): Channel 1 (L): off=00; on=01 Channel 2 (R): off=00; on=02 Channel 3 (C): off=00; on=04 Channel 4 (LFE): off=00; on=08 Channel 5 (LS): off=00; on=10 Channel 6 (RS): off=00; on=20
9	nnH	Monitor Output Channel Status using Input Analog Switches Bit Map (sum values from all six channels): Channel 1 (L): normal=00; mute=01 Channel 2 (R): normal=00; mute=02 Channel 3 (C): normal=00; mute=04 Channel 4 (LFE): normal=00; mute=08 Channel 5 (LS): normal=00; mute=10 Channel 6 (RS): normal=00; mute=20
10	F7H	EOX, End of System-Exclusive Message

Function: Monitor Output Level - Normal

Byte	Value	Description
1	F0H	System-Exclusive Message
2	00H	1 st Byte of Studio Tech ID
3	00H	2 nd Byte of Studio Tech ID
4	56H	3 rd Byte of Studio Tech ID
5	07H	Product ID (Model 74)
6	03H	Function, Monitor Output Level - Normal
7	nnH	Monitor Output Level, MSB, range 00-7F
8	0nH	Monitor Output Level, LSB, range 0-1
9	F7H	EOX, End of System-Exclusive Message

Notes: Control console sends new value each time monitor output level is changed.

Monitor output level is 8-bit precision, spread over two MIDI bytes: 00H 00H lowest; 7FH 01H highest. MIDI byte 7 is monitor output level bits 2-8; MIDI byte 8 is monitor output level bit 1.

Dim function is performed by control console and is sent using monitor output level command.

Function: Monitor Output Level - Reverse

Byte	Value	Description
1	F0H	System-Exclusive Message
2	00H	1 st Byte of Studio Tech ID
3	00H	2 nd Byte of Studio Tech ID
4	56H	3 rd Byte of Studio Tech ID
5	07H	Product ID (Model 74)
6	04H	Function, Monitor Output Level - Reverse
7	nnH	Monitor Output Level, MSB, range 00-7F
8	0nH	Monitor Output Level, LSB, range 0-1
9	F7H	EOX, End of System-Exclusive Message

Notes: Not sent by control console. Provided for special applications.

Monitor output level is 8-bit precision, spread over two MIDI bytes: 00H 00H highest; 7FH 01H lowest. MIDI byte 7 is monitor output level bits 2-8; MIDI byte 8 is monitor output level bit 1.

Dim function is performed by control console and is sent using monitor output level command.

Function: Stereo to Mono Downmix

Byte	Value	Description
1	F0H	System-Exclusive Message
2	00H	1 st Byte of Studio Tech ID
3	00H	2 nd Byte of Studio Tech ID
4	56H	3 rd Byte of Studio Tech ID
5	07H	Product ID (Model 74)
6	05H	Function, Stereo to Mono Downmix
7	0nH	Status, range 0-3: 0=off 1=on, L+R sent to left and right channels of monitor output 2=on, L+R sent to center channel of monitor output 3=on, Bandpassed L+R sent to center channel of monitor output
8	F7H	EOX, End of System-Exclusive Message

Function: 5.1 to Stereo Downmix

Byte	Value	Description
1	F0H	System-Exclusive Message
2	00H	1 st Byte of Studio Tech ID
3	00H	2 nd Byte of Studio Tech ID
4	56H	3 rd Byte of Studio Tech ID
5	07H	Product ID (Model 74)
6	06H	Function, 5.1 to Stereo Downmix
7	0nH	Status, range 0-1: 0=off 1=on
8	F7H	EOX, End of System-Exclusive Message

Function: Cue Audio

Byte	Value	Description
1	F0H	System-Exclusive Message
2	00H	1st Byte of Studio Tech ID
3	00H	2nd Byte of Studio Tech ID
4	56H	3rd Byte of Studio Tech ID
5	07H	Product ID (Model 74)
6	07H	Function, Cue Audio
7	0nH	Cue Audio Source: 0=No Source 1=Stereo B 2=Source follows L/R Output
8	F7H	EOX, End of System-Exclusive Message

Function: Talkback

Byte	Value	Description
1	F0H	System-Exclusive Message
2	00H	1st Byte of Studio Tech ID
3	00H	2nd Byte of Studio Tech ID
4	56H	3rd Byte of Studio Tech ID
5	07H	Product ID (Model 74)
6	08H	Function, Talkback
7	0nH	Talkback Level, range 0-7, 7 is loudest
8	0nH	Talkback Status: n=0 Off n=1 On, Source is Model 75 Mic n=2 On, Source is Line-Level Talkback Input
9	F7H	EOX, End of System-Exclusive Message

TO/FROM
MODEL 68A
CENTRAL
CONTROLLER
(9-PIN D-SUB)

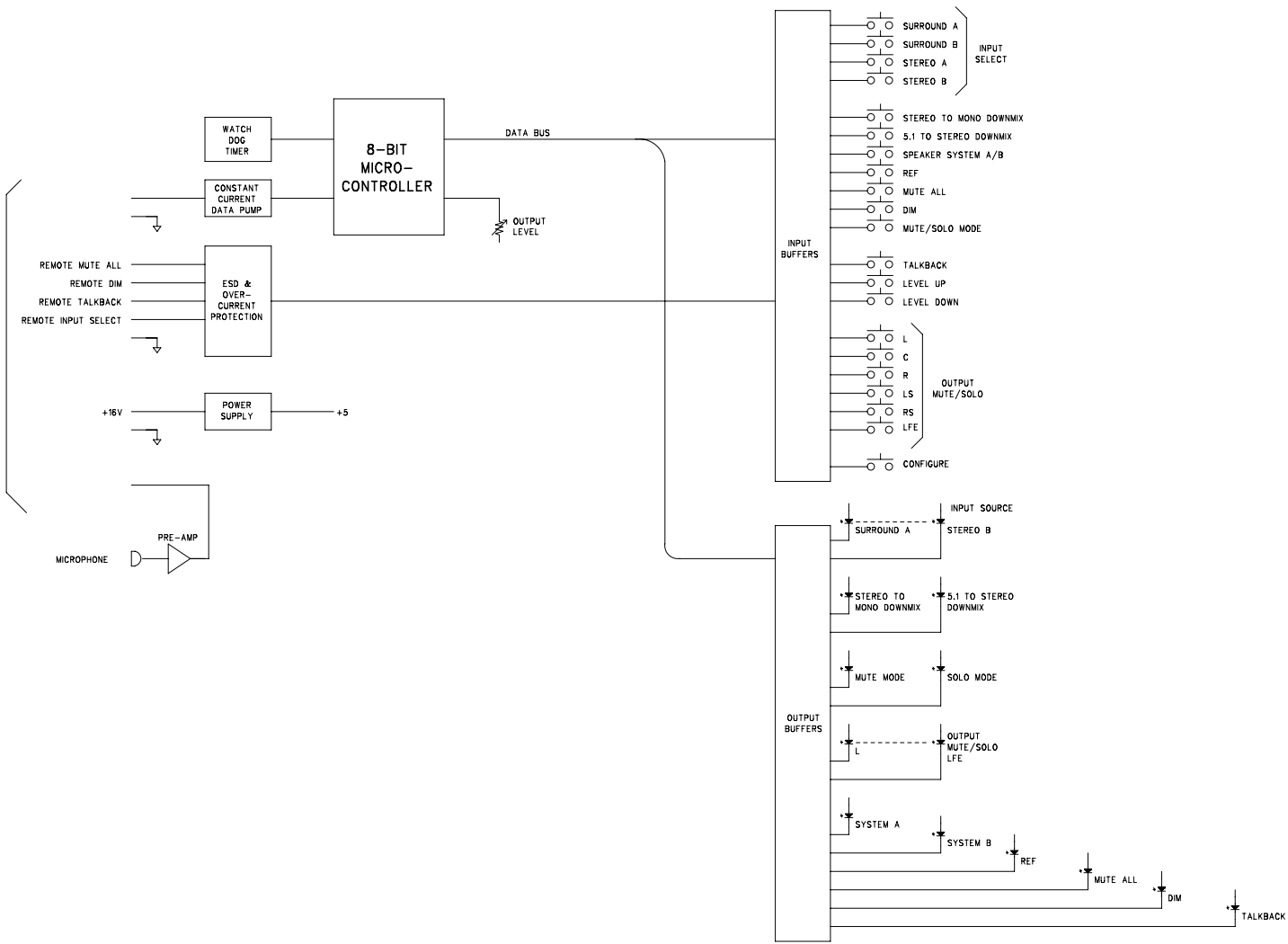

M75BD_B

STUDIO TECHNOLOGIES, INC.		
MODEL 75 CONTROL CONSOLE BLOCK DIAGRAM		
DRAWING NO. 31168	DATE 01/10/06	PAGE 01 OF 01

