

# **Model 5132 Party-Line Interface Module**

## **User Guide**

Issue 1, December 2011

This User Guide is applicable for serial numbers  
M5132-00151 and later

**Copyright © 2012 by Studio Technologies, Inc., all rights reserved**  
[www.studio-tech.com](http://www.studio-tech.com)

This page intentionally left blank.

# Table of Contents

Introduction.....	5
Installation .....	8
Configuration .....	10
Operation.....	10
Technical Notes .....	13
Specifications .....	17
Appendix A—Model 5132 Front Panel and Printed Circuit Board (PCB) Dimensions.....	18

This page intentionally left blank.

# Introduction

The Model 5132 Party-Line Interface Module is a compact, self-contained unit for use in custom broadcast, live-performance, and general party-line intercom applications. The module provides a high-quality 2-channel party-line to analog line-level (“4-wire”) audio signal interface in an easy to use yet technically sophisticated package. The module’s basic functions include two channels of 2-wire-to-4-wire conversion with auto-null capability, input and output level metering, a +28 volt DC party-line power source with two channels of 200 ohm intercom audio termination, and DC output control and status monitoring. With the internal party-line power source enabled, beltpack user devices can be directly connected. Alternately, the Model 5132 can be connected into an existing party-line system that includes a power source and intercom audio terminations. Two sets of 4-wire analog inputs and outputs interface the Model 5132 with a variety of external audio transport, intercom, and infrastructure equipment. Module operation requires only an externally-provided source of 12 volts DC. Advanced features include remote control and monitoring capability.

Applications for the Model 5132 include sports broadcasting booth packages, remote news gathering “fly packs,” stadium audio/video interface (I/O) locations, and government/corporate/performance space/aerospace test infrastructure projects. The number of Model 5132 modules used in a project can vary widely—from one to dozens. And in each case the performance will be completely “pro” with audio, reliability, and installation flexibility matching that of larger-scale products. Typical applications will find the Model 5132’s 4-wire audio inputs and outputs being interfaced with fiber-optical transport modules, matrix intercom systems, and audio/video routers. The flexibility of the Model 5132’s party-line intercom interface allows connection either directly to intercom beltpack devices or into an existing party-line intercom system.

The Model 5132 provides a full-featured 2-channel interface which includes two 2-wire-to-4-wire hybrid circuits with automatic nulling capability. The analog hybrid circuitry provides excellent audio quality and high return-loss. Audio level meters provide confirmation of system performance during setup and operation. The Model 5132’s 2-wire party-line interface is accessible using a 3-pin male XLR

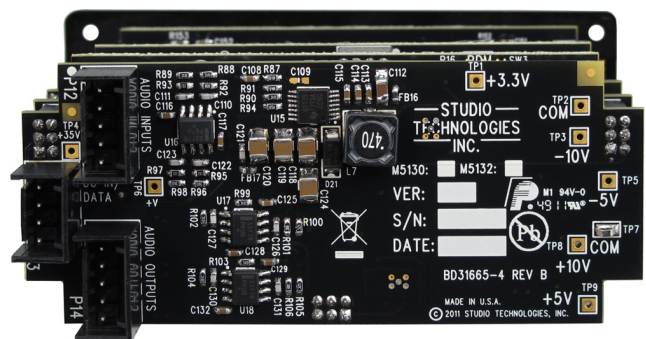

connector. This allows industry-standard party-line intercom user belt packs to be directly interfaced. With a maximum output current of 180 milliamperes, up to three of the popular RTS® BP325 devices can be directly connected. Devices from Clear-Com® are also compatible.

For applications with an existing party-line intercom system the Model 5132 is also directly compatible. The internal power source and 200 ohm terminations can be disabled by selecting the appropriate operating mode by way of a pushbutton switch on the Model 5132's front panel.

All line-level audio inputs and outputs were carefully designed for use in permanent as well as field applications. Filtering on the inputs minimizes the chance that radio frequency (RF) energy will interfere with audio input sources. Other components were included to address ESD ("static") and DC over-voltage conditions. The DC power input is protected from accidental polarity reversal.

For operation, the Model 5132 only requires connection of analog audio inputs and outputs, along with an external source of nominal 12 volts DC. The acceptable input voltage range is 10 to 18, allowing a variety of power sources to be utilized. Internal power supply circuitry within the Model 5132 creates the voltages required for the analog and digital circuitry.

Standard connectors are used throughout the Model 5132. The user-accessible party-line intercom connection is made using a 3-pin male XLR connector. Line-level audio input and output connections are made using 5-position, 0.1-inch "header" connectors. The DC power input and data bus connections use a 4-position, 0.1-inch header. Low-cost IDC (insulation displace-

ment) mating connectors allow simple interconnection with the audio input, audio output, and DC/data signals.

For compliance with international broadcast audio level standards two versions of the Model 5132 are available. The Model 5132S supports SMPTE® audio levels where the analog audio reference level is +4 dBu. The Model 5132E supports applications that require European Broadcast Union (EBU) compliance with an analog audio reference level of 0 dBu.

Model 5132 Party-Line Interface Modules do not include a mounting enclosure or chassis. They are intended for mounting in custom 19-inch rack panels, equipment boxes, broadcast furniture, "NEMA" I/O boxes, or other specialized settings. It is expected that integration firms will create applications that use Model 5132 modules as part of complete broadcast, production, corporate, and government solutions.

## Party-Line Interface

The Model 5132's party-line interface is very flexible, offering excellent performance when operating both "stand alone" or interconnected with an existing intercom system. When enabled, the party-line intercom power supply circuitry provides a low-noise, current-limited source with a nominal 28 volt DC output. Termination networks provide the required 200 ohm impedance for the audio signals associated with the two party-line intercom channels. With these features the Model 5132's party-line intercom interface is essentially identical to that created by stand-alone intercom power supplies or powered master stations.

Two LEDs, located on the Model 5132's front panel, provide an indication of the

power source's on/off state and the condition of the DC voltage present on pin 2. Logic circuitry contained within the Model 5132 monitors the voltage on pin 2. When the Model 5132 is providing intercom power this function will monitor pin 2 for a low-voltage/over-current condition. If detected, the DC output will automatically enter a protection mode. Once the fault condition is removed normal operation will again resume. When an external source of intercom power is present the pin 2 status LED offers the user a simple "go/no go" indication for rapid troubleshooting.

An auto 4-wire mute function is active whenever the Model 5132's operating mode has been set to support external party-line intercom power. (In this case an external source of DC voltage and 200 ohm terminations is necessary for correct operation.) The auto 4-wire mute function helps to ensure that the Model 5132's audio interface circuitry will remain stable in "real-world" situations. This unique feature makes certain that objectionable audio signals, such as oscillations and "squeals," will not be sent to the associated 4-wire devices should a valid party-line intercom circuit not be connected.

## **Analog Hybrids with Auto Nulling**

The 2-wire-to-4-wire hybrids provide low noise and distortion, good frequency response, and high return-loss ("nulling"), even when presented with a wide range of party-line conditions. Unlike telephone-line ("POTS") oriented DSP-based hybrid circuits, the Model 5132's analog circuitry maintains extended frequency response. With a wide bandwidth, natural-sounding

voice signals can be sent to, and received from, the connected party-line user devices. This bandwidth also allows high-frequency "call light" and "mic kill" signals to pass through to connected equipment.

The Model 5132's sophisticated auto nulling function uses analog circuitry under microprocessor control to achieve significant trans-hybrid loss. This return-loss "null" is achieved by making a series of software-directed adjustments to account for the resistive, inductive, and capacitive conditions that are present on the connected party-line user devices and associated cabling. Whenever a user presses the Model 5132's auto null button digital circuitry adjusts the 2-wire-to-4-wire hybrids to achieve their maximum return-loss for both interface channels in less than 15 seconds. While the nulling process is automatic, it only takes place upon user request. The resulting null parameters are stored in non-volatile memory.

## **4-Wire Audio Interfaces**

Two sets of analog line-level inputs and outputs are associated with the 4-wire portion of the Model 5132's circuitry. These are intended to interconnect with a variety of devices, including matrix intercom systems, audio-over-fiber transmission systems, and related specialized audio equipment. The input and output circuitry is electronically balanced and capacitor coupled to minimize the chance that hum, noise, or interfacing issues will occur. The two Model 5132 versions allow compatibility with equipment that supports SMPTE (+4 dBu) and EBU (0 dBu) analog audio level standards.

## Indicators

The Model 5132 contains four 5-segment LED level meters. Two meters display the level of the signals being received from the party-line channels and two display the level being sent to the party-line channels. At the time of installation and setup the meters are invaluable in helping to confirm correct operation. During normal operation the meters offer rapid confirmation of the audio signals flowing into and out of the module. Four additional LED indicators are also provided offering status indications of the party-line DC power, pin 2 status, auto null, and remote control data functions.

## Pro Audio Quality

The Model 5132's audio circuitry was designed in the spirit of professional audio equipment rather than that found in typical party-line intercom gear. High-performance components are used throughout, providing low-distortion, low-noise, and high headroom. The party-line DC power source offers a unique level of performance—its ability to deliver power while maintaining audio quality is simply unmatched.

## Installation

Integration of the Model 5132 into the selected application is quite simple, only requiring connecting analog audio inputs and outputs along with DC power. The audio signals have a nominal level of either +4 or 0 dBu, depending on the Model 5132 version being installed. The DC power source is nominal 12 volts with an acceptable range of 10 to 18 volts. After the connections have been completed, the module can then be secured into the designated mounting location.

## Audio Inputs

The Model 5132 allows two channels of analog line-level audio to be connected. Each signal is associated with one of the two party-line interface channels. The input circuitry is electronically balanced and capacitor coupled. The nominal input level of Model 5132S (SMPTE) version modules is +4 dBu with a maximum allowable input level of +24 dBu. The nominal input level of Model 5132E (EBU) version modules is 0 dBu with a maximum allowable level of +18 dBu.

Connections to the audio inputs are made using a 5-position header connector located on the Model 5132's rear-most circuit board. For connecting to balanced sources the signal + (high), signal – (low), and common/shield connections should be used. With unbalanced sources connect source signal high to the Model 5132's signal + (high) and source signal low to both the signal – (low) and common/shield connections.

The required mating receptacle is from the AMP MTA100 series of IDC (insulation displacement) connectors. Parts are available that are compatible with 22-28 AWG wire. The color of the receptacle indicates the intended wire gauge. The part number for compatibility with 24 AWG is AMP 3-643814-5. This receptacle is white in color.

For effective and reliable termination a semi-automatic termination tool is recommended. At Studio Technologies we get excellent results using the AMP 58074-1 handle assembly with associated die 58246-1. (For reference you'll find these items stocked by Digi-Key: [www.digikey.com](http://www.digikey.com).) This tool assembly will support 22-28 AWG and stranded wire should be used.

The audio inputs should be connected following the details in Figure 2.

### **Audio Inputs**

---

1. Common/Shield
  2. + CH1
  3. – CH1
  4. + CH2
  5. – CH2
- 

**Figure 2. Audio inputs**

### **Audio Outputs**

Associated with each of the Model 5132's two party-line interface channels is a balanced (differential), line-level analog audio output. The circuitry is electronically balanced and capacitor coupled. The nominal output level of a Model 5132S (SMPTE) version module is +4 dBu with a maximum output level of +24 dBu. The nominal level of a Model 5132E (EBU) version module is 0 dBu with a maximum level of +18 dBu.

Connections to the outputs are made using a 5-position header connector located on the Model 5132's rear-most circuit board. For connection to balanced inputs on related equipment the signal + (high) and signal – (low) connections should be used. Pin 1, common/shield, may or may not need to be connected as dictated by the specific installation.

When interfacing the outputs to unbalanced inputs on associated equipment connect only to the Model 5132's signal + (high) and common/shield. Do not make any connections to the Model 5132's – (low) terminals. The required mating

receptacle is the same type as described for the audio inputs.

The audio outputs should be connected following the details in Figure 3.

### **Audio Outputs**

---

1. Common/Shield
  2. + CH1
  3. – CH1
  4. + CH2
  5. – CH2
- 

**Figure 3. Audio outputs**

### **DC Power and Data**

A 4-position header, located adjacent to the audio input and output headers, is used to connect DC power and RS-485 data to the Model 5132. A source of nominal 12 volts DC, with an acceptable range of 10 to 18, is required for Model 5132 operation. The maximum current is 800 milliamperes at 12 volts DC.

For remote control operation an RS-485 data bus connection from a compatible Studio Technologies' remote access module is required. Most applications will only have the DC power connections implemented so these two pins would typically remain unconnected.

The mating connector is, like the audio inputs and outputs, compatible with the AMP MTA series of IDC receptacles. It's recommended that 22 AWG or larger wire be used for the DC power input. For 22 AWG wire the receptacle would be AMP part number 3-644540-4 with a body color

of red. For 24 AWG the AMP part number is 3-643814-4 and the color is white. Refer to Figure 4 for details.

### DC Input/Data

1. – DC (Common)
2. +DC (10-18 volts)
3. + Data (RS-485)
4. – Data (RS-485)

**Figure 4. DC Input/Data**

## Mounting

The Model 5132 is intended for mounting into an installation-specific enclosure or rack panel. Refer to Appendix A for the required mounting opening and screw locations. Please contact the factory to discuss mounting options.

# Configuration

## RS-485 Address ID

One configuration setting must be performed for applications that implement remote control of Model 5132 functions. Up to eight Model 5132 modules can “share” an RS-485 data bus but each must have a unique address ID. Selecting the device’s address ID involves setting three DIP switches. Refer to Figure 5 for details.

## Operation

The Model 5132 is designed for continuous operation with no internal adjustment, calibration, or maintenance required.

Two pushbutton switches allow the user to select the on/off status of the party-

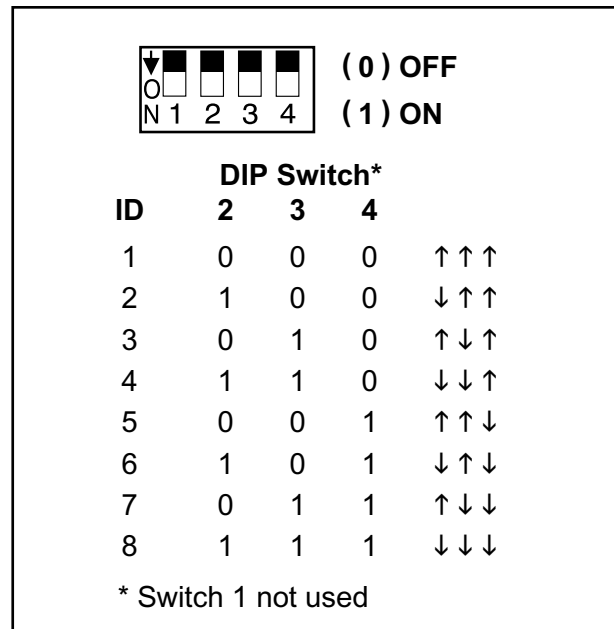

**Figure 5. RS-485 address ID settings**

line power source as well as activating the auto null function. Depending on how the Model 5132 is going to be used the party-line power source can be enabled or disabled. It would be enabled whenever user beltpacks are going to be the only devices connected directly to the Model 5132. The power source should be turned off whenever the Model 5132 is going to be connected to an existing party-line intercom system that includes power and audio terminations. The auto null function is used whenever significant changes are made to the number of user devices or the interface cabling connected to the party-line interface. This is a simple process only requiring the pressing of the auto null pushbutton switch. On the audio input side, maintaining the correct levels coming from the audio sources is very important. This will ensure proper signal levels are being presented to users and maintain optimal audio fidelity. The audio meters, party-line power status LED, and pin 2 status LED

will assist users in confirming that correct operation is taking place. In addition, the under-voltage shut-down function will help to protect the party-line DC power circuitry should a fault condition be detected.

## Party-Line Power

A pushbutton switch and status LED is associated with the Model 5132's party-line power source. A momentarily press of the button will "toggle" (alternate) between the power on and power off modes. When the LED is lit 28 volts DC will be applied to pin 2 of the XLR connector. In addition, audio terminations (200 ohm AC loads) are enabled on the two intercom channels. (Technically, independent nominal 200 ohm AC-coupled loads are placed from pin 2 to pin 1 and from pin 3 to pin 1.) If user beltpack devices are going to be directly connected and powered by the Model 5132 the party-line power function must be enabled.

If the Model 5132's party-line intercom interface is going to be connected to an existing party-line intercom system the Model 5132's party-line power source should be turned off. In this mode the power intercom power status LED will not be lit, +28 volt DC will not be applied to pin 2, and the audio terminations will be removed.

If the Model 5132's power source is enabled when the interface is connected to an existing party-line intercom system no damage will result. But the audio levels will no longer be correct as the intercom channels will now be "double terminated." The Model 5132's 200 ohm terminations will be active at the same time as those of the external intercom power supply. The intercom "bus" terminal will drop to some-

thing on the order of 100 ohms and the audio level will drop by at least 6 dB. This will cause audio level issues for users as well as preventing satisfactory Model 5132 auto nulling from taking place.

## Auto Null

The Model 5132 contains circuitry to automatically null the two 2-wire-to-4-wire interfaces. Normally this process is performed at the time of initial Model 5132 user set up and operation, but there's no reason why "auto nulling" can't be initiated anytime one desires. The only time that auto null must be performed is if conditions have changed vis-à-vis the party-line intercom user devices and wiring connected to a Model 5132's party-line intercom interface connector. Even a slight change to a party-line intercom circuit, such as adding or removing a section of cable, is sufficient to require that the auto null process be performed.

A pushbutton switch, located on the Model 5132's front panel, is used to activate the auto null process. To initiate auto null requires simply pressing and releasing ("tapping") the button. An LED provides a visual indication of the auto null process, flashing when the auto null process is active. The sequence takes approximately 12 seconds.

An auto null sequence begins with the muting of the analog 4-wire audio input and output signal paths. This is followed by a short period of 24 kHz signal that is sent out both the party-line intercom interface channels. This will turn off microphones on those connected user devices that are compatible with the RTS TW-series "mic kill" protocol. The actual auto nulling process is performed next. A series of tones will be sent out the party-line interface channels. Other Model 5132 circuitry,

under software control, will rapidly perform adjustments to achieve the best null possible. After the adjustments have been made the results are stored in nonvolatile memory. Once the process is complete the analog 4-wire audio input and output paths are again activated.

If possible, prior to performing an auto null it's polite to warn all personnel who are actively using the connected party-line intercom devices. The tones sent to the party-line intercom channels during the nulling process are not excessively loud or obnoxious, but most users might want to remove their headsets during the process. In addition to warning users it might be a good time to ask them to mute any active microphones. While the automatic "mic kill" signal will apply to many user devices it may not apply to all. Muting microphones is significant as obtaining a "deep" null requires that no extraneous signals be present on the intercom circuit.

## Level Meters

The four audio level meters on the Model 5132 are calibrated differently from typical "VU" meter scales. Their "steps" are labeled in reference to the level of the signals being sent to, and received from, the party-line interface. During operation the green "0" LEDs will light in response to audio levels of  $-10$  dBu being present on the party-line channels. When a 5132S (SMPTE level) module has its "0" LEDs lighting it corresponds to  $+4$  dBu being present on its associated analog input or output connections. In the case of a 5132E (EBU level) module the analog input and output level would be  $0$  dBu. The ballistics of the meters is also different, being a cross between VU and peak.

The four green LEDs of each meter indicate that the levels are in the normal range. The yellow LED lights when a signal is approximately  $6$  or more dB above the nominal ( $-10$  dBu to or from the party-line channel) level. An optimal input signal will result in the four green LEDs lighting almost solidly with the yellow LED lighting only on peak signals.

## Party-Line Intercom Output

If the Model 5132's party-line intercom power source is enabled one or more party-line user devices can be connected to the party-line interface connector. The only restriction on the number of units that can be connected is that the total current draw must be equal to or less than  $180$  milliamperes. Broadcast-standard devices such as the RTS BP325 are directly compatible and will provide excellent performance.

To clarify, these signals are present on the party-line intercom interface's 3-pin male XLR connector: pin 1 is power and audio common; pin 2 is  $28$  volts DC with channel 1 audio; pin 3 is channel 2 audio. The nominal audio output level on the two channels is  $-10$  dBu, no matter if the module is a 5132S or a 5132E. The maximum current draw from pin 2 to pin 1 is  $180$  milliamperes. The circuitry associated with pin 3 is protected from damage should pin 2 (nominal  $28$  volts DC) become accidentally connected to it.

## DC Voltage Monitoring

The pin 2 status LED can be a highly useful "tool" for understanding the status of the party-line intercom connection. It does this by providing an indication of the DC voltage that is present on pin 2 (with respect to

pin 1) of the Model 5132's party-line interface XLR connector. The Model 5132's microcontroller integrated circuit, under software control, "watches" to ensure that the DC voltage present on pin 2 of the party-line intercom interface is at an acceptable level for the selected operating mode. When the Model 5132's party-line power source is enabled the under-voltage threshold for pin 2 is 24 volts. This is four volts less than the normal level of 28 volts DC. The LED will "flash" at a moderate cadence if the voltage on the interface falls below the acceptable 24 volt value. This can be caused by a temporary over-current or short-circuit condition, such as when interconnecting user devices to the party-line intercom interface using portable cabling.

If the Model 5132 is providing party-line power in an under-voltage condition that's present for a continuous 1-second period it will cause a fault condition to be recognized. The pin 2 status LED will indicate this condition by changing from being continuously lit to flashing. In addition, the output voltage on the party-line intercom interface circuit will automatically shut down to an essentially off condition. A 5-second "cool-down" period will then take place, after which the output voltage will again become active. As soon as the output is enabled normal output voltage monitoring will again take place. A continuous short circuit presented to the party-line intercom output will result in a continuous 4-seconds-on, 5-seconds-off error cycle. It's important to note that during the 5-seconds-off period no voltage monitoring takes place. Removing the fault condition will not result in the output voltage immediately turning on again; the 5-second shut-down period must first elapse.

If the Model 5132's operating mode is selected for external party-line power the pin 2 status LED will function in a slightly different way. It will light whenever the voltage on pin 2 is greater than approximately 12 volts DC. The LED will not light if the voltage is less than 12 volts DC and the auto 4-wire mute function will become active. When the auto 4-wire mute function is active both the 4-wire audio inputs and outputs will mute. These simple functions will allow a user to quickly determine if an active party-line circuit has been connected as well as maintaining audio integrity.

## Technical Notes

### Maintaining Correct Input Signal Levels

The Model 5132's audio inputs and outputs are designed for compatibility with either SMPTE (5132S) or EBU (5132E) audio level standards. Applying signals to the audio inputs at a significantly lower level than the intended nominal will reduce the signal-to-noise ratio (raising the perceived noise floor) and can prevent the connected user devices from operating optimally. Applying signal levels significantly higher than nominal will reduce the headroom and greatly increase the chance of reaching audio "clipping." Obviously, these cautions are not unique to the Model 5132, but apply to most audio equipment. The front-panel level meters provide an easy means of confirming that a Model 5132 is being presented with the correct audio levels.

For the Model 5132S the nominal input and output signal levels are +4 dBu. For the Model 5132E the nominal levels are 0 dBu. For both versions the nominal

output level to the two channels associated with the party-line output is  $-10$  dBu. (Of course pin 2 on the party-line interface connector has both DC and audio present on it.)

To confirm correct party-line intercom operation at locations away from where the Model 5132 is installed, it's possible to use the Model 72 Level Meter/Interface, also available from Studio Technologies. The Model 72 is a compact, portable device that plugs directly into a party-line intercom or IFB circuit and provides two useful functions. Two 5-segment LED meters display the audio levels present on pins 2 and 3. Two "dry" line-level audio outputs are also provided, one for each channel. Complete information on the Model 72 is available on the Studio Technologies website.

## **Party-Line Interface Current Draw**

The Model 5132's party-line output is designed to provide up to 180 milliamperes of DC current. By design, the power supply circuit is protected so that an overload condition, or even a complete short circuit, should not cause damage. Exceeding 180 milliamperes for more than one second will cause the auto shut-down mode to become active. A continuous overload condition will cause the output voltage to cycle through a 4-seconds-on, 5-seconds-off sequence. Restoring the output load to be within the rated 180 milliamperes will allow the party-line output to again operate normally. In extreme cases, such as where the Model 5132 is located in an environment with elevated temperatures, a few minutes may be required from the time an overload condition is removed to when normal operation will again take place. Please

don't test the Model 5132's ability to sustain frequent overload or short-circuit conditions! The long-term reliability of the unit can be impacted by the stresses caused by these fault conditions.

The pin 2 power status LED makes it easy to know if an excessive load, or a short circuit, is being placed on the party-line output. Technically the LED, under software control, provides a direct indication of the party-line's DC output voltage. And the output voltage is directly related to the amount of current being drawn.

The LED lights steadily when the party-line DC output voltage is within its normal range. During normal operation the DC level on pin 2 of the XLR output connector will be approximately 28 volts. The LED will begin to flash on and off if the level falls below approximately 24 volts DC for at least one second. This will typically occur because the current draw is greater than nominally 180 milliamperes.

There's really only one piece of advice when it comes to understanding how to use the pin 2 power status LED: if it flashes there's a problem that must be corrected! The most likely cause will be too many user devices being connected to the party-line output connector. It's also possible that a wiring problem could cause a partial or full short circuit between the output XLR's pin 1 (common) and pin 2 (power with channel one audio) pins. Troubleshooting should prove quick and easy. Begin by disconnecting the party-line user devices. Observe the status LED and see if the problem has gone away. If not, review the interconnecting cables and find the fault condition. Within five seconds of the problem being "cleared" the status LED will stop flashing.

## Cable Length

There are no “hard and fast” rules defining the maximum cable length possible when connecting user devices to the Model 5132’s party-line intercom output and using the Model 5132’s party-line intercom power source. The maximum cable length is directly related to the amount of resistance in the connecting cable; the lower the resistance per foot (or meter), the longer the cable can be (although cable capacitance affects high-frequency performance, resistance is the limiting factor in most cases). For example, a contemporary microphone cable is Belden 1172A which has 18 ohms resistance per conductor pair per 1000 feet. Since we’re using 2-conductor pairs to carry the signal (pins 1 and 2) you’d get 36 ohms per 1000 feet of cable. By knowing the cable resistance value, along with the minimum voltage and maximum load current required by a party-line intercom user device, a simple “ohms law” calculation will tell you the maximum cable length.

Let’s use the example of an RTS BP325 beltpack being connected to the Model 5132’s party-line output XLR connector. We’ll select Belden 1172A as the interconnecting cable. For correct operation, a BP325 needs at least 18 volts DC between pins 1 and 2 of its interface connector. And the BP325 has a measured maximum current draw of approximately 60 milliamperes. The Model 5132 presents a party-line voltage of 28 volts across pins 1 and 2 and can supply a maximum current of 180 milliamperes. (As the BP325’s current draw is well within the Model 5132’s capability, this is not a limiting factor.) The difference

between the voltage supplied by the Model 5132 (28 volts) and the voltage required by the BP325 (18 volts) allows a 10 volt maximum drop over the interconnecting cable. Using the current draw and maximum voltage drop figures, the maximum cable resistance can easily be calculated: 10 volts divided by 0.060 amperes equals 167 ohms. And finally, with 1172A’s 36 ohms (total) per 1000 feet of cable, a maximum of approximately 4600 feet (1424 meters) of cable can be used and still be less than or equal to 167 ohms. Using this example as a guide, entering the appropriate values will allow you to determine the maximum cable length for your application.

## Cabling Issues – Crosstalk

The Model 5132’s party-line interface conforms to the broadcast-industry standard for sending DC power and two channels of audio over a single pair with shielded audio cable. This implementation allows standard portable cables, such as those used for microphone signals, to interconnect various party-line user devices. This method is undoubtedly convenient and practical, but is not without limitations. The main audio quality issue is the possibility of crosstalk between the two audio channels. This issue arises due to the capacitance presented by the two wires that form the twisted pair. The greater the capacitance presented and the longer the cable run, the greater the crosstalk. Is this normally a problem during actual use? No. But it’s something that should be noted.

## Software Version Display

After the Model 5132's power-up sequence is completed, the unit's LEDs are used to automatically display the software version number. This is useful when working with factory personnel on application support and troubleshooting situations. The five LEDs associated with the channel 1 audio level meter are used to display the major release number with a range of 1 through 5. The five LEDs associated with the channel 2 audio level meter are used to display the release sub-number which ranges from 0 to 5. (No lit channel 2 LEDs indicates sub-number 0.) The software version number will display for approximately one second after the power-up sequence has completed but before normal operation will begin. Refer to Figure 6 for a detailed view of the LEDs and the corresponding software version numbering scheme.

Note that while it's easy to determine which software version is loaded into the Model 5132 a trip back to the factory is required to update it. The 8-bit microcontroller that provides the unit's logic "horsepower" also includes internal FLASH memory. This nonvolatile memory is used to store the operating software ("firmware"). Re-programming this memory requires using a specialized programming unit. While not outrageous in price, it still costs in the range of US\$500. The programmer uses a ribbon cable and socket to interface with a 6-pin "header" on one of the Model 5132's printed circuit boards. And, as you would guess, once connected, reprogramming takes only a matter of seconds. But unfortunately the programmer is not something that would be found in a typical "field shop" or repair facility.

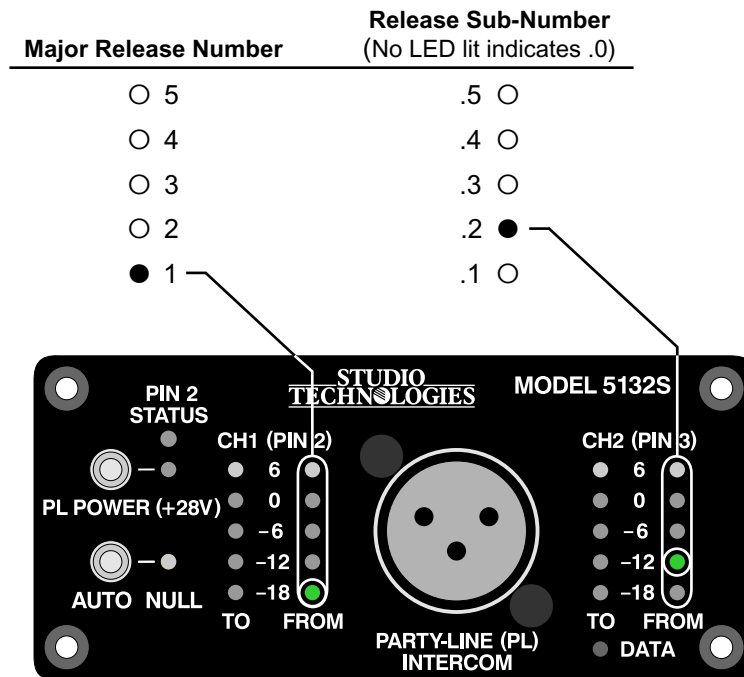

**Figure 6. Detail of front panel showing the level meter LEDs that display the software version. In this example, the software version is 1.2.**

# Specifications

## **General Audio:**

### **Frequency Response (analog input to party-line interface):**

- 3.0 dB @ 80 Hz
- 2.5 dB @ 100 Hz
- 2.3 dB @ 20 kHz
- 3.0 dB @ 24 kHz

### **Distortion (THD+N, measured at 1 kHz, analog input to party-line interface):**

- Party-Line Interface Pin 2:** 0.06%
- Party-Line Interface Pin 3:** 0.02%

### **Signal-to-Noise Ratio (measured at 1 kHz, analog input to party-line interface):**

- Party-Line Interface Pin 2: 60 dB
- Party-Line Interface Pin 3: 86 dB

## **Audio Inputs: 2**

**Type:** analog, electronically balanced, capacitor-coupled, 20 k ohms

**Nominal Level:** +4 dBu (Model 5132S), 0 dBu (Model 5132E)

**Maximum Level:** +24 dBu

## **Audio Outputs: 2**

**Type:** analog, electronically balanced, capacitor-coupled, intended to drive balanced loads of 2 k ohms or greater

**Nominal Level:** +4 dBu (Model 5132S), 0 dBu (Model 5132E)

**Maximum Level:** +24 dBu into 10 k ohms

Source Impedance: 200 ohms, nominal, differential

## **Party-Line Intercom Interface:**

**Type:** 2-channel party-line, unbalanced (common on pin 1, DC modulated with channel 1 audio on pin 2, channel 2 audio on pin 3)

**Compatibility:** single- and dual-channel intercom system and user devices from vendors such as RTS® and Clear-Com®

**Nominal Audio Level:** -10 dBu

## **Maximum Audio Output Level:**

- Pin 2:** +9 dBu with +23 dBu (Model 5132S) on audio input
- Pin 3:** +10 dBu with +24 dBu (Model 5132S) on audio input

**DC Output Voltage (pin 2 to pin 1):** 28 volts nominal, selectable on/off

**DC Output Current (pin 2 to pin 1):** 180 milliamperes maximum

**Impedance (pin 2 to pin 1; pin 3 to pin 1), local party-line power enabled:** 200 ohms, nominal

**Impedance (pin 2 to pin 1; pin 3 to pin 1), local party-line power disabled:** >10 k ohms

## **Hybrids: 2**

**Topology:** 3-section analog circuitry compensates for resistive, inductive, and capacitive 2-wire party-line loads

**Nulling Method:** automatic upon user initiation, processor implements digital control of analog circuitry; settings stored in non-volatile memory

**Nulling Line Impedance Range:** 120 to 240 ohms

**Nulling Cable Length Range:** 0 to 3500 feet

**Trans-Hybrid Loss:** >45 dB, typical at 1 kHz

**Meters:** 4, 5-segment LED, modified VU ballistics

**Remote Control Capability:** audio level monitoring, pin 2 DC output status, auto null activation

## **Connectors:**

**Party-Line Intercom:** 3-pin male XLR

**Audio Inputs and Outputs:** 2, 5-position male header, AMP® MTA-100-series, part number 2-644486-5

**DC Input/Data:** 4-position male header, AMP MTA-100-series, part number 2-644486-4

**Power Requirement:** 12 volts DC nominal, 800 mA max; acceptable range 10-18 volts DC, 950 mA max at 10 volts

## **Dimensions (Overall):**

- 3.75 inches wide (9.5 cm)
- 1.69 inches high (4.3 cm)
- 2.30 inches deep (5.8 cm)

**Mounting:** requires custom implementation; no mounting method provided

**Weight:** 0.2 pounds (91 g)

Specifications and information contained in this User Guide subject to change without notice.

# Appendix A

## Model 5132 Front Panel and Printed Circuit Board (PCB) Dimensions

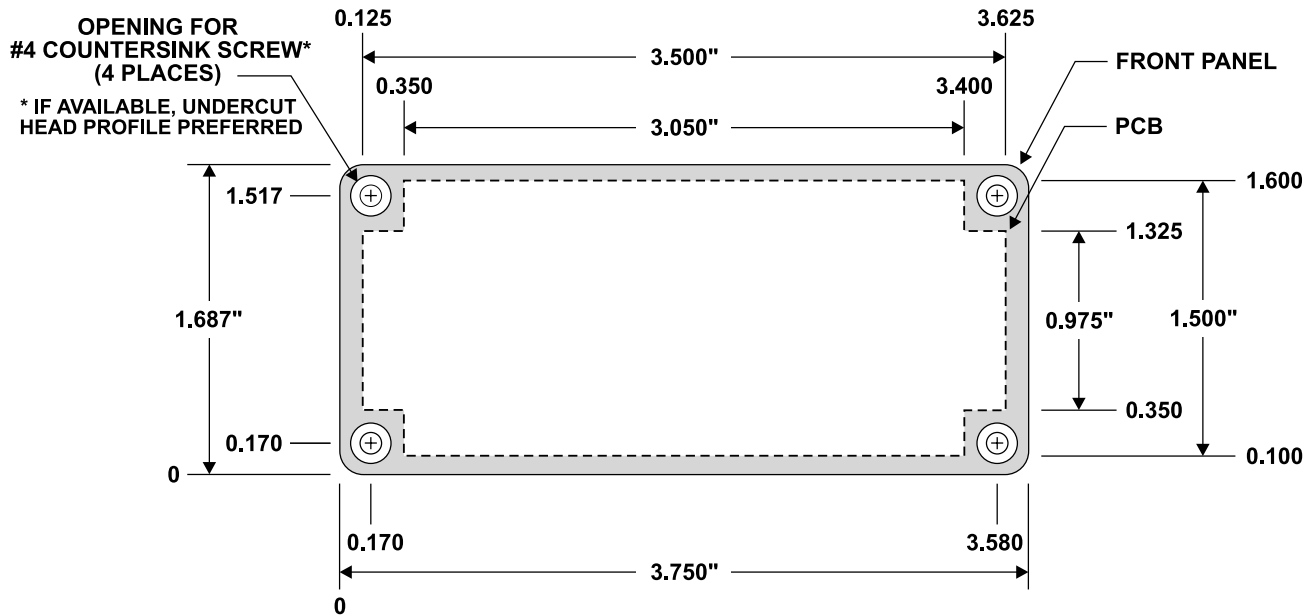

NOTE: OPENING MUST BE MADE IN CUSTOM-MOUNTING ARRANGEMENT SO THAT PCB IS ALLOWED TO FREELY PASS THROUGH.

This page intentionally left blank.